

MICROCRUISE 4

INSTALLATION and OWNER'S MANUAL

THIS MANUAL, YOUR KIT AND YOU

This Cruise Control Kit is a microprocessor based Cruise Control. It is designed for ease of installation and can be used with most cars, light trucks and vans. Carefully follow the installation procedures in this manual for best results.

TO VIEW THE INSTALLATION VIDEO VISIT OUR WEBSITE AT WWW.ROSTRA.COM

DO NOT INSTALL THIS SYSTEM ON A DIESEL POWERED VEHICLE WHICH HAS A MANUAL TRANSMISSION WITHOUT A DISENGAGEMENT SWITCH (250-4206) ON THE CLUTCH PEDAL ASSEMBLY

Your vehicle must have a VSS (Vehicle Speed Sensor) wire or an available signal generator for installation of this Cruise Control. Please consult vendor's Application Guide. Low displacement engines with limited vacuum will get better performance if a vacuum reservoir is installed. Vacuum reservoirs, pumps, regulators and other accessories are available from your dealer, automotive service center or most automotive parts outlets.

All through the instructions there are WARNINGS, CAUTIONS, AND NOTES that are meant to make it easier for you to put the Cruise Control on your vehicle and safer to use. We have gathered these tips from people across the country who have told us about their problems and how they worked them out. Even with all these reports from the field, we cannot cover every condition which you might encounter, there are just too many different vehicle makes and models. We do our best to tell you how to handle most vehicles, but we must Depend On Your Good Judgment for dealing with the rest.

Therefore, we believe you can understand why we strongly urge you to think carefully about what could happen to you, your passengers and your vehicle if you use any tools, parts, fastening methods, routing or procedures which are not described in this manual.

There is NO drain on the battery if the control switch is left on. The Cruise Control needs no regular service.

WARNING:

Failure to follow the instruction manual could not only cause the Cruise Control to work improperly, but could cause the Cruise Control to function incorrectly, possibly causing damage to your vehicle and/or injury or death to both you and your passengers.

WARNING:

If you question the applications of the Cruise Control, please consult the applicable application guide. Only install on approved applications.

TABLE OF CONTENTS

I.	Parts List and Parts Diagram.....	4-5
II.	Helpful Hints.....	6
III.	Switch Settings.....	7
IV.	Installation Procedures.....	8
	A. Servo Assembly Mounting.....	8
	B. Throttle Connection.....	9
	1. Measuring Throttle Travel.....	9
	2. Attaching Cable Assembly to Throttle.....	10
	a. Pulley Assembly using Loop Cable.....	10
	b. Pulley Assembly using T-Bar Cable.....	11
	c. Pedal Attachment.....	11
	d. Ford Throttle.....	12
	e. General Motors and Chrysler Throttle using Two Bead Connector.....	12-13
	f. Throttle Pulley Stud using Throttle Adaptor Clip with Cable.....	13
	C. Anchoring Cable Assembly.....	14
	1. Snap-In-Adaptor.....	14
	2. General Motors Blank Anchor.....	14-15
	3. Tube Clamp.....	15
	D. Vacuum Line Installation.....	16
	E. Harness Assembly.....	17
	F. Sealing Bulkhead.....	17
	G. Cruise Control Switch Installation.....	17-18
	H. Wiring Attachments to Vehicle.....	18
V.	Self Diagnostic Procedures.....	19-20
VI.	Wiring Diagram.....	20
VII.	Testing TACH Signal and Control Switch.....	21
VIII.	Operating Procedures.....	22
IX.	Technical Service Information.....	23

PARTS LIST

ITEM	PART#	DESCRIPTION	QTY.	ITEM	PART#	DESCRIPTION	QTY
1	250-3694	Servo Assembly	1	18	*	Vacuum Tee- 3/16" x 3/16" x 3/16"	1
2	250-3695	Harness Assembly	1	19	*	Vacuum Tee- 1/4" x 1/4" x 1/4"	1
3	250-3697	Cable Assembly	1	20	*	Vacuum Reducer- 1/4" x 3/16"	1
4	250-3696	Servo Bracket	1	21	*	Vacuum Tube- 7/32" x 1-3/8"	1
5	*	7-1/2" Tie Strap	10	22	*	Bead Chain	1
6	250-3700	Extension Bracket	1	23	*	Snap-in Adaptor	1
7	*	Tube Clamp 1/4"	1	24	*	Bead Chain Connector Cover	3
8	*	Tube Clamp 5/16"	1	25	*	Bead Chain Connector	3
9	*	Tube Clamp 3/8"	1	26	*	Two Bead Connector	1
10	*	Threaded Tube Clamp	1	27	*	GM Hat Clip	1
11	*	Screw #10- 32 x 1/2"	3	28	*	Loop Cable	1
12	*	Nut - #10 - 32	3	29	*	Self Strip Conn. 18-22	2
13	*	Self Strip Conn. 14-18	2	30	*	4" Tie Strap	1
14	*	Screw 1/4" - 14 x 3/4"	4	31	*	Nut - 1/4" - 20	2
15	*	Sealing Putty	1	32	*	Eyelet Connector	1
16	250-3425	Convolutud Tubing	1	33	*	Throttle Clip w/ Cable	1
17	250-3016	Vacuum Hose- 5/32" x 48"	1				

Disengagement Switch use 250-4206
Vacuum Reservoir use 250-3417 or 250-6019
Vacuum Regulator use 250-4115
***Order Kit 250-2213 and receive parts indicated**

PARTS DIAGRAM

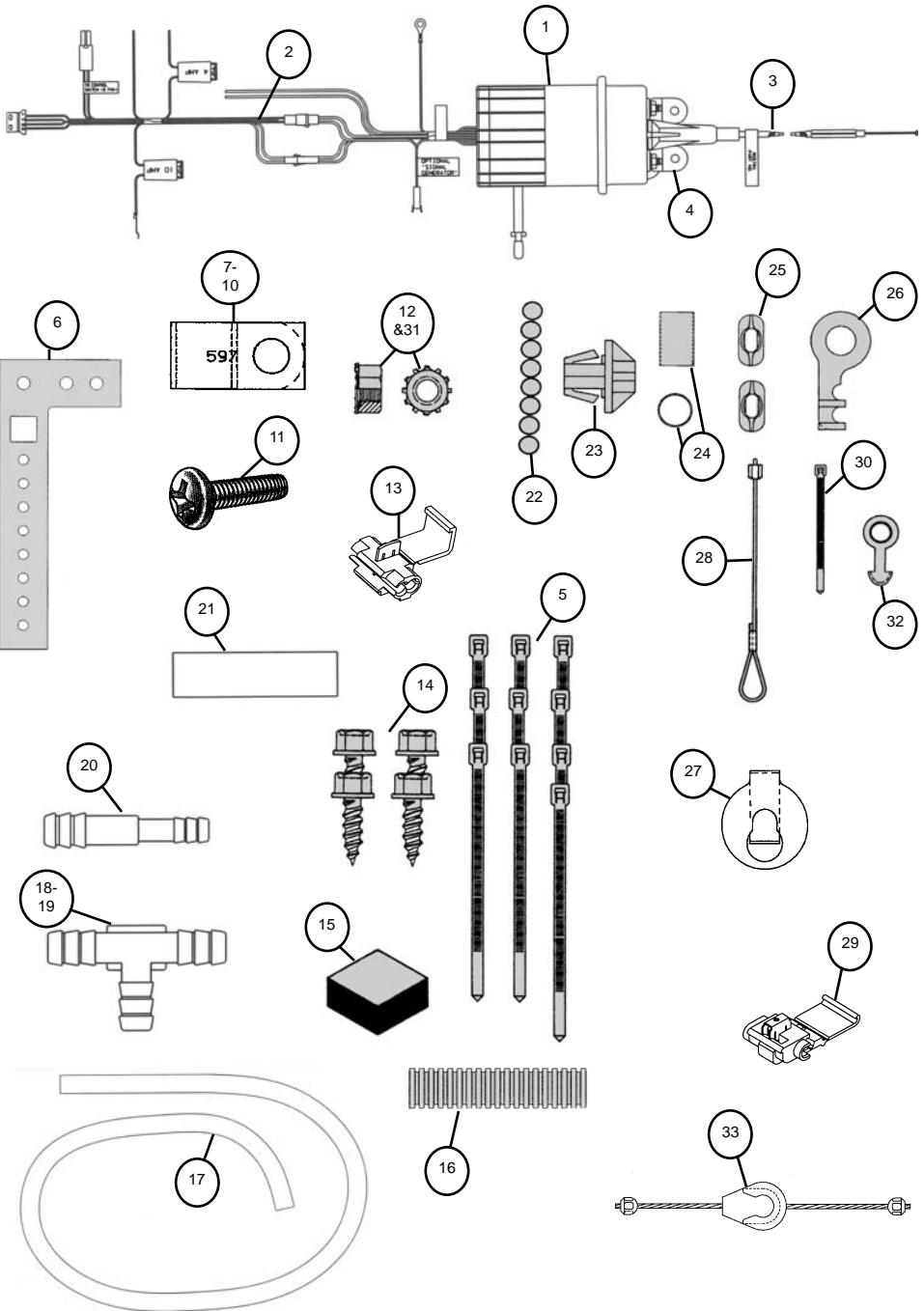

HELPFUL HINTS

1. Before Starting Installation:

Familiarize yourself with the Installation Instructions and Cruise Control's components.

2. Air Bag and Anti-Theft Radio:

- A. If vehicle is equipped with an ANTI-THEFT RADIO, the radio code must be written down prior to disconnecting battery cable. The code must be re-entered when the negative battery cable is reinstalled.
- B. If vehicle is equipped with an AIR BAG, it is advisable to disconnect negative battery cable. However, remember that some vehicles retain power to the air bag system when battery is disconnected.

3. Removal of Negative Battery Cable:

Remove the negative battery cable before installing the **Cruise Control** components as a safety precaution. **(Figure A)**

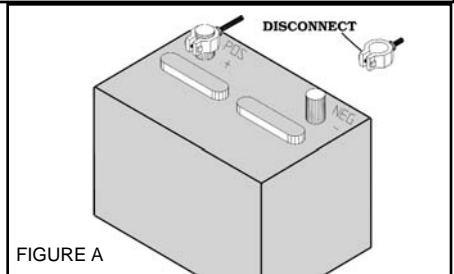

4. Self Stripping Connector:

When installing Self Stripping Connector, follow these four steps: **(Figure B)**

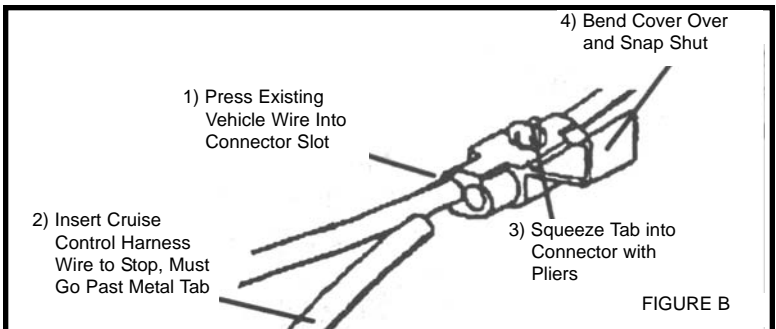

5. Accessory Power:

When installing the special terminal into fuse panel of vehicle, See **(Figure C)**

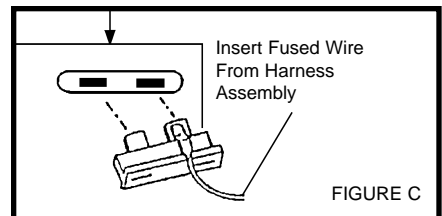

SWITCH SETTINGS

The **ACTUATOR ASSEMBLY** must be programmed for the vehicle on which it is installed. The **TEN (10)** programming switches must be set according to the chart below in order for the **Cruise Control** to operate properly.

NOTE 1: Both the **VSS (Gray)** and **TACH (Blue)** wires must be connected. *(If vehicle VSS wire is not used, an auxiliary road speed source must be used.)* See Form#2482 Vehicle Technical Information Guide (supplied in kit) for VSS and TACH wire information

NOTE 2: If using an "Open Circuit" control switch with the **Cruise Control**, Switch number **7** will have to be **OFF**. On "OPEN CIRCUIT" switch, the "ACCEL" slide switch will be pushed toward passenger window. If unsure whether control switch is "OPEN CIRCUIT" or "CLOSED CIRCUIT", look at control switch box label.

NOTE 3: If any of the **10** switches need to be changed after installation of the **Cruise Control**, CONTROL SWITCH AND VEHICLE IGNITION SWITCH MUST BE IN THE OFF POSITION TO RESET THE CRUISE CONTROL.

PROGRAMMING SWITCHES ARE FOUND BEHIND HARNESS END CAP ON SERVO ASSEMBLY.

SWITCHES ARE SHOWN IN THE "ON" POSITION

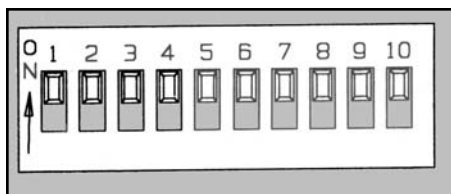

PROGRAMMING SWITCHES		FUNCTIONS			
GAIN (SENSITIVITY)	Low	Medium (Normal)	High		
SWITCH 1	OFF	OFF	ON		
SWITCH 2	OFF	ON	ON		
Note: If your Cruise Control surges or is too sensitive - set Gain to Low					
Note: If your Cruise Control seems slow in controlling or responding to set speed - set Gain to High					
PULSES PER MILE	2000	4000	5000	8000	NOTE: Use 2000 PPM When using magnet package
SWITCH 3	ON	OFF	ON	OFF	
SWITCH 4	ON	ON	OFF	OFF	
ENGINE	3 & 4 Cylinder	5 & 6 Cylinder	8 Cylinder		
SWITCH 3	ON	OFF	OFF		
SWITCH 6	OFF	ON	OFF		
CONTROL SWITCH	OFF: Open Circuit Control Switch				
SWITCH 7	ON: Closed Circuit Control Switch				
NOTE: If unsure of Control Switch , see Control Switch test or label on box					
CENTERING	OFF: Low (Slow pull-up)		(Normal)		
SWITCH 8	ON: High (Fast pull-up)				
NOTE: If your Cruise Control drops 1 mph or more when setting, then set Centering to High					
TRANSMISSION	OFF: Manual Transmission				
SWITCH 9	ON: Automatic Transmission				
VSS SOURCE	OFF: Vehicles using Auxiliary VSS (Signal Generator or Magnets) and Ford Vehicles				
SWITCH 10	ON: Vehicle's Own VSS (ECM)				

INSTALLATION PROCEDURES

A. SERVO ASSEMBLY MOUNTING

NOTE

DO NOT MOUNT THE SERVO ASSEMBLY IN THE FOLLOWING AREAS:

- * Under the fender.
- * Under the vehicle.
- * Directly to the engine or bulkhead.
- * With the cable pointed down.
- * Near sharp, hot or moving objects.
- * Near ignition coil [No closer than 255mm (10")].
- * In the passenger compartment (Noise).
- * Where it will interfere with service checks.

1. Select a possible location to mount your **SERVO ASSEMBLY**, set the **SERVO ASSEMBLY** unmounted in that area. The reason for leaving the **SERVO ASSEMBLY** unmounted is to make sure the **HARNES ASSEMBLY** will reach the **SERVO ASSEMBLY** and the **CABLE ASSEMBLY** will reach the throttle attaching point.
2. Once you have confirmed that the **HARNES ASSEMBLY** and the **CABLE ASSEMBLY** will reach their respective locations, mount the **SERVO ASSEMBLY** in the spot you have selected with Screws provided in the kit. **(Figure 2)**

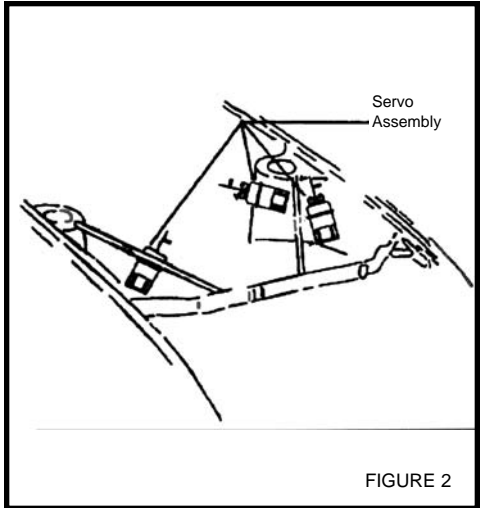

FIGURE 2

CAUTION:

Failure to follow the instruction manual could not only cause the Cruise Control to work improperly, but could cause the throttle to hang up, possibly causing damage to your vehicle and injury to you and your passengers

INSTALLATION PROCEDURES

B. THROTTLE CONNECTION

1. MEASURING THROTTLE CABLE TRAVEL

THIS IS A VERY IMPORTANT STEP. FAILURE TO DETERMINE THROTTLE CABLE TRAVEL COULD CAUSE DAMAGE TO YOUR VEHICLE AND/OR CRUISE CONTROL.

MEASURE ONLY WITH THE ENGINE OFF. The **CRUISE CABLE** moves **41mm (1-5/8")**.

To measure throttle travel, measure the distance from Position "A" (*Idle*) to Position "B" (*Wide Open Throttle*).

- Make a mark on the throttle cable when the throttle is in the idle position. **Figure 3**
- Depress accelerator pedal and make a mark on the throttle cable when the throttle is in the wide open position. **Figure 4**
- Measure the Distance "C" between the two marks. **Figure 5** If the distance is greater than **41mm (1-5/8")**, go to **Page 10**; If it is less, go to **Step d**.
- If the throttle travel is less than **41mm (1-5/8")**, you must use **BEAD CHAIN** to provide slack.

NOTE: Slack is the distance the **CABLE ASSEMBLY** moves before the throttle starts to move.

Each bead of the chain added will give you 1/8" (3 mm), you will need one (1) bead.

NOTE: To add beads you must use the **BEAD CHAIN, BEAD CHAIN CONNECTOR** and the **BEAD CHAIN COVER**. Do not count the bead used with the **BEAD CHAIN CONNECTOR**.

After determining your throttle travel, continue to the next section.

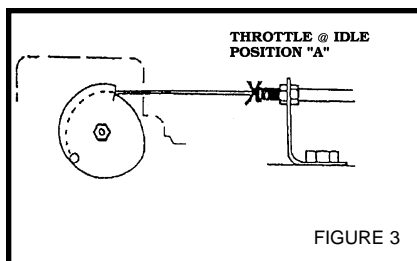

FIGURE 3

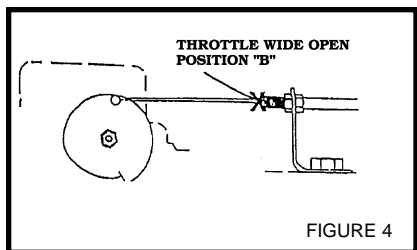

FIGURE 4

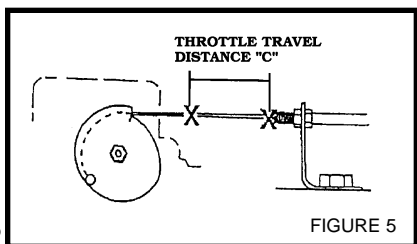

FIGURE 5

CAUTION:

Failure to follow the instruction manual could not only cause the Cruise Control to work improperly, but could cause the throttle to hang up, possibly causing damage to your vehicle and injury to you and your passengers

INSTALLATION PROCEDURES

2. ATTACHING CABLE ASSEMBLY TO THROTTLE

This section will cover the proper ways to use the hardware available. Each method contains sample illustrations showing how the connector is used in an actual installation. It must be noted, however, that you should have an understanding of how each attachment method works so that a proper installation is achieved.

There are **six (6)** different types of throttle connections.

- a. Pulley Assembly Using The **LOOP CABLE**
- b. Pulley Assembly Using **T-BAR ADAPTOR**
- c. Pedal Attachment.
- d. **Ford™** Throttle
- e. **General Motors™** and **Chrysler™** Throttle Using **TWO BEAD CONNECTOR**
- f. Throttle Stud Attachment using **ADAPTER CLIP WITH CABLE**

NOTE:

When using the Bead Chain Connector to connect the Bead Chain to the Cable Assembly you must always use the Bead Chain Cover. (Figure 6) Failure to use the Bead Chain Cover could possibly cause the Bead Chain or the Cable Assembly to hang in the Bead Chain Connector causing the throttle to be held in a partially open position. This condition could occur when the Cruise Control is not being used.

a. Pulley Assembly Using The **LOOP CABLE**

1. On some vehicles it may be necessary to remove the air cleaner so the throttle pulley segment is showing.
2. Set the pulley segment in an **OPEN** throttle position, and remove the throttle cable from the pulley.
3. Hold the **LOOP CABLE** between the holes in each side of the pulley. Slide the barrel at the end of the throttle cable through the slotted hole, then through the **LOOP CABLE** and into the second hole. **Figure 7**
4. Connect the **LOOP CABLE** to the **CABLE ASSEMBLY** using the **BEAD CHAIN CONNECTOR**.
5. To secure the **LOOP CABLE** to the throttle cable, punch a small hole in the **BEAD CHAIN COVER** and slide the **TIE STRAP (4")** through the hole and secure to the existing throttle cable. **Figure 8**

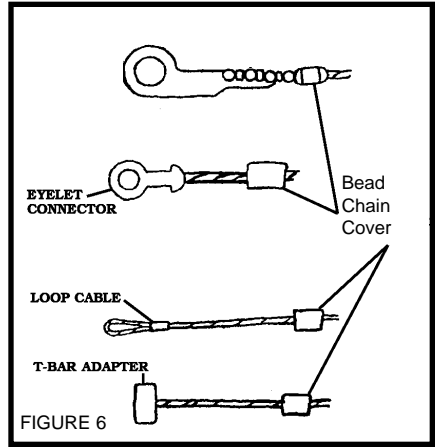

FIGURE 6

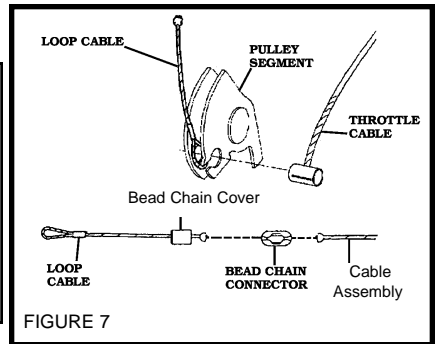

FIGURE 7

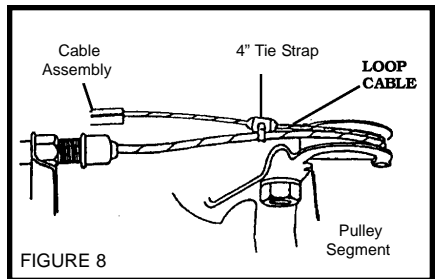

FIGURE 8

WARNING

If the **LOOP CABLE** is not secured to the existing throttle cable, it could come out of the pulley segment possibly causing the throttle to be held in a partially open position.

INSTALLATION PROCEDURES

2. ATTACHING CABLE ASSEMBLY TO THROTTLE (Continued)

b. Pulley Assembly (Dual) Using The T-BAR ADAPTOR (250-4184)

1. Remove air cleaner to expose the dual pulley segments.
2. Find the blank anchor that is located above the throttle anchor. Follow the instructions for anchoring the **CRUISE CABLE**, See **Page 15**.
3. Attach a **BEAD CHAIN CONNECTOR** onto the **CABLE ASSEMBLY**. **Figure 9**
4. Attach the **T-BAR ADAPTOR** to the top pulley segment. Slide the **BEAD CHAIN COVER** onto the **T-BAR ADAPTOR**.
5. Attach the **T-BAR ADAPTOR** to the **BEAD CHAIN CONNECTOR**. Make sure to slide the **BEAD CHAIN COVER** over the **BEAD CHAIN CONNECTOR**. **Figure 10**

c. Pedal Attachment

1. Select a **TUBE CLAMP** that fits around the top of the accelerator pedal shaft. Make sure the tabs of the **TUBE CLAMP** point away from the bulkhead.
2. Attach the **BEAD CHAIN** to the **CABLE ASSEMBLY** with a **BEAD CHAIN CONNECTOR**. Make sure to use a **BEAD CHAIN COVER**.
3. After you determine the length of **BEAD CHAIN** needed to attach to the accelerator pedal shaft, cut **BEAD CHAIN** and attach to the **EYELET CONNECTOR**. Make sure to use a **BEAD CHAIN COVER**.
4. Put **SCREW #10-32 x 1/2** through the holes in the **TUBE CLAMP**. Slide the **EYELET CONNECTOR** over the screw. Thread **NUT #10-32** onto the screw and tighten. **Figure 11**

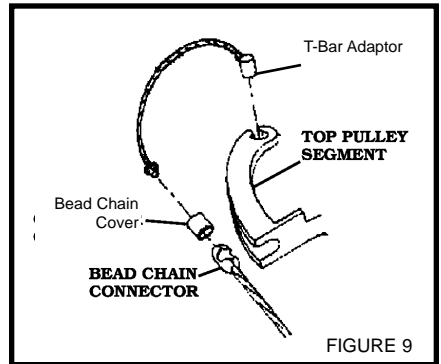

FIGURE 9

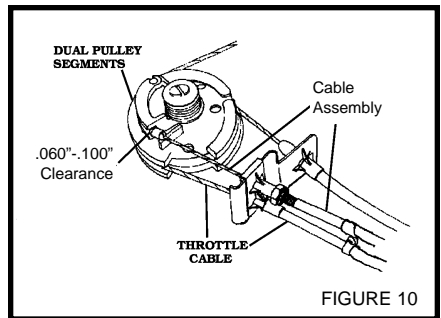

FIGURE 10

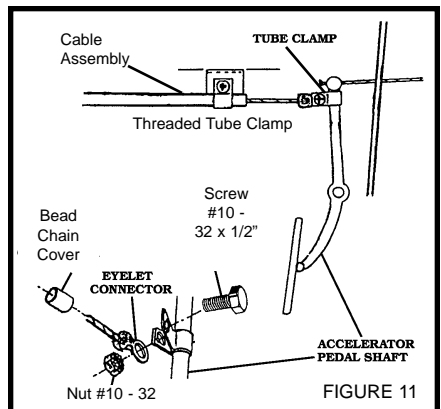

FIGURE 11

WARNING

Failure to follow the instruction manual could not only cause the **Cruise Control** to work improperly, but could cause the throttle to hang up, possibly causing damage to your vehicle and injury and/or death to you and your passengers.

INSTALLATION PROCEDURES

2. ATTACHING CABLE ASSEMBLY TO THROTTLE (Continued)

d. Ford™ Throttle

1. Select a **TUBE CLAMP** that fits the throttle cable. Make sure the tabs of the **TUBE CLAMP** point away from the carburetor or air throttle, this will prevent the throttle from hanging. **Figure 12**
2. Attach **CABLE ASSEMBLY** to the **EYELET CONNECTOR**.

NOTE: Use the **BEAD CHAIN COVER**.

3. Put **SCREW #10-32 x 1/2** through the holes in the **TUBE CLAMP**. Slide the **EYELET CONNECTOR** over the screw. Thread the **NUT #10-32** onto the screw and tighten. **Figure 12**
4. **Figure 13** is an example of a **Ford™** Throttle connection using the **TUBE CLAMP**.

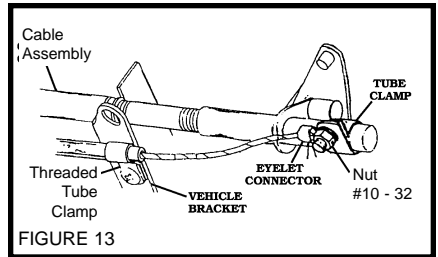
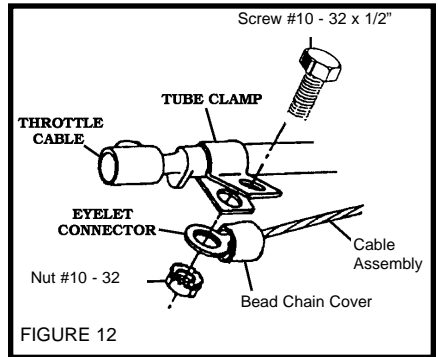

e. General Motors™ and Chrysler™ Throttle using TWO BEAD CONNECTOR.

1. Most **General Motors™** vehicles and many **Chrysler™** vehicles can use the **TWO BEAD CONNECTOR** to attach the **CABLE ASSEMBLY**. **Figure 14**

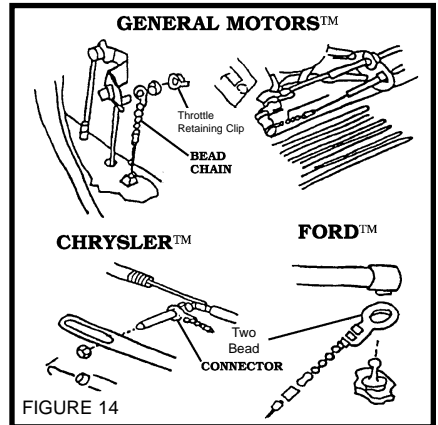

WARNING

Failure to follow the instruction manual could not only cause the **Cruise Control** to work improperly, but could cause the throttle to hang up, possibly causing damage to your vehicle and injury and/or death to you and your passengers.

INSTALLATION PROCEDURES

2. ATTACHING CRUISE CABLE TO THROTTLE (Continued)

e. **General Motors™** and **Chrysler™** Throttle using **TWO BEAD CONNECTOR**. (Continued)

2. Attach the **BEAD CHAIN** to the **TWO BEAD CONNECTOR**. Secure beads by folding down the metal tabs. **Figure 15**

The following parts will be used when installed properly:

TWO BEAD CONNECTOR, BEAD CHAIN, BEAD CHAIN CONNECTOR, and BEAD CHAIN CONNECTOR COVER

3. Remove clip or pin which retains throttle cable (and washer if provided) and install **TWO BEAD CONNECTOR** on the same side of throttle cable that the **CABLE ASSEMBLY** will be anchored (this is necessary so that **CABLE ASSEMBLY** and throttle cable will not cross).

4. The **TWO BEAD CONNECTOR** may need to be bent so that it clears the throttle cable. **Figure 16** Use the **TIE STRAP (4")** to hold the **TWO BEAD CONNECTOR** to the sleeve of the throttle cable.

Figure 16

f. **General Motors™, Ford™** and **Chrysler™** Throttle using **Throttle Clip w Cable**.

1. Some **General Motors™, Ford™** and **Chrysler™** vehicles have an attachment stud on the throttle pulley.

2. Slide a **BEAD CHAIN CONNECTOR COVER** over the **CRUISE CABLE**, then attach the **BEAD CHAIN CONNECTOR** to the cable. Attach the **THROTTLE CLIP W CABLE** to the **BEAD CHAIN CONNECTOR** and slide the **CONNECTOR COVER** over the **BEAD CHAIN CONNECTOR**. **Figure 17**

3. Slide the **THROTTLE CLIP** over the throttle pulley attachment stud. Push the **THROTTLE CLIP** onto the stud until it snaps firmly onto the stud.

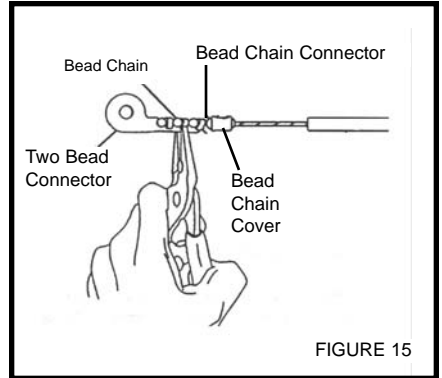

FIGURE 15

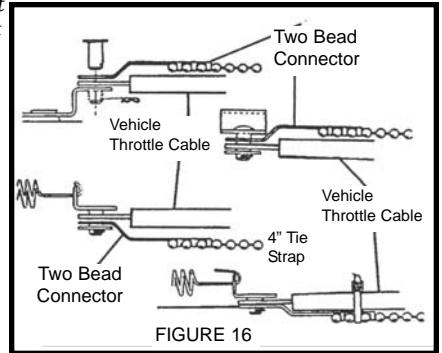

FIGURE 16

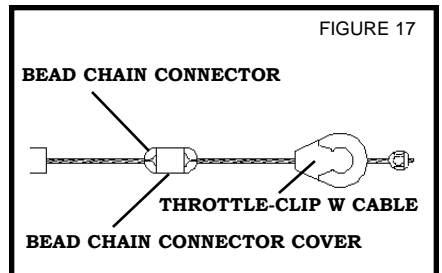

FIGURE 17

NOTE

After the **CABLE ASSEMBLY** has been attached, manually move the throttle to assure the **CABLE ASSEMBLY** does not hang up on any part of the vehicle.

INSTALLATION PROCEDURES

C. ANCHORING CABLE ASSEMBLY

There are **three (3)** types of connectors used to anchor the **CABLE ASSEMBLY**:

1. **SNAP-IN ADAPTOR**
2. **General Motors™ Blank Anchor**
3. **TUBE CLAMP**

1. SNAP-IN ADAPTOR

- a. Before using the **SNAP-IN ADAPTOR**, remove the Adjustable Sleeve from the **CABLE ASSEMBLY**. To use the **SNAP-IN ADAPTOR**, it will be necessary to form threads on the end of the **CABLE ASSEMBLY**. This is easily accomplished by placing the **1/4" - 20 NUT** on the end of the **CABLE ASSEMBLY** with your fingers. Then using an **7/16"** box end wrench and turning the Nut clockwise until the desired amount of threads have been formed. **Figure 18**
- b. After the threads have been formed, screw the **SNAP-IN ADAPTOR** onto the **CABLE ASSEMBLY**. **Figure 19**
- c. The **SNAP-IN ADAPTOR** snaps into the square hole of the **EXTENSION BRACKET** **Figure 20** or snaps into an existing square hole on the vehicle (*common on GM™ vehicles*). **Figure 21**

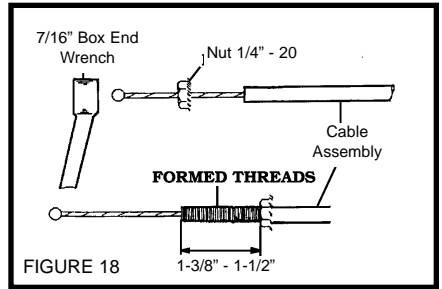

FIGURE 18

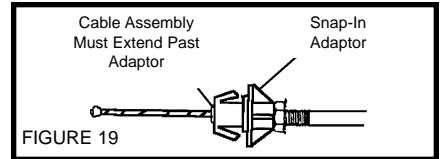

FIGURE 19

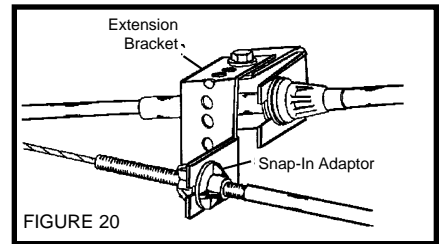

FIGURE 20

2. General Motors™ Blank Anchor

- a. To locate the blank anchor on **General Motors™** vehicles, it is necessary to remove the air cleaner. The blank anchor is located above the throttle anchor.
- b. This anchor is hollow except at one end. Use a **6.4mm (.25")** bit drill as shown in **Figure 22**.

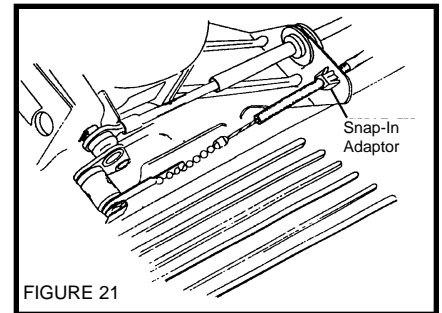

FIGURE 21

NOTE

CABLE ASSEMBLY must extend past the end of the **SNAP-IN ADAPTOR** on all applications.

- c. Before using the **1/4" - 20 Nut**, remove the Adjustable sleeve from the **CRUISE CABLE**. Then use the **LOCKWASHER NUT** to form threads on the end of the **CABLE ASSEMBLY**. This is easily accomplished by placing the **1/4" - 20 NUT** on the end of the **CABLE ASSEMBLY** with your fingers. Then use an **7/16"** box end wrench and turn the nut clockwise until the desired amount of threads have been formed **Figure 18**

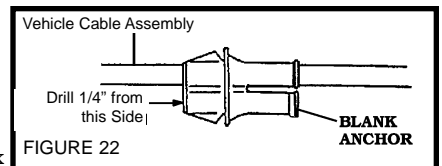

FIGURE 22

INSTALLATION PROCEDURES

C. ANCHORING CABLE ASSEMBLY (CONTINUED)

2. General Motors™ Blank Anchor

- d. Insert the **CABLE ASSEMBLY** through the blank anchor and thread the other **1/4" - 20 NUT** in place. **Figure 23**

NOTE

If you do not use the other **1/4" - 20 NUT**, install a **TUBE CLAMP** and the **THREADED TUBE CLAMP** 6" to 7" from the anchor point. (**Figure 24**) This will keep the **CABLE ASSEMBLY** from backing out of the anchor.

- e. The **1/4" - 20 NUT** can also be used if there is a pre-existing **1/4"** hole in a bracket on the vehicle or if it is possible to drill a **1/4"** hole in a bracket on the vehicle. **Figure 25**

CAUTION:

When using a **TUBE CLAMP** on the **CABLE ASSEMBLY**, the **ADJUSTABLE SLEEVE** MUST be used to prevent slippage or binding of cable.

3. TUBE CLAMP

- a. Before using the **TUBE CLAMP** slide the **ADJUSTABLE SLEEVE** into a location on the **CABLE ASSEMBLY** so you can center the **TUBE CLAMP** to avoid slippage. **Figure 26**
- b. The **TUBE CLAMP** may be used to anchor the **CABLE ASSEMBLY** to an existing throttle cable bracket. **Figure 27** In some cases you can drill a **3/16"** hole in the bracket.
- c. The **TUBE CLAMP** may also be used to anchor the **CRUISE CABLE** using the **EXTENSION BRACKET**. **Figure 28**

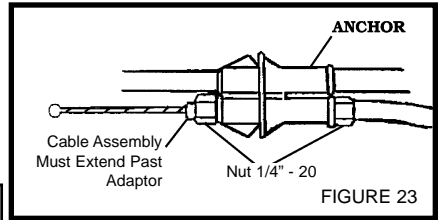

FIGURE 23

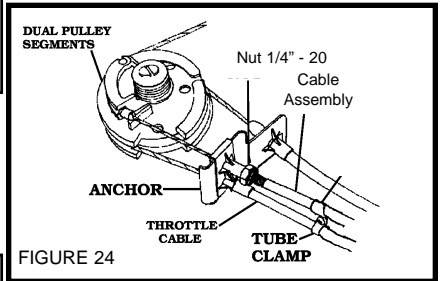

FIGURE 24

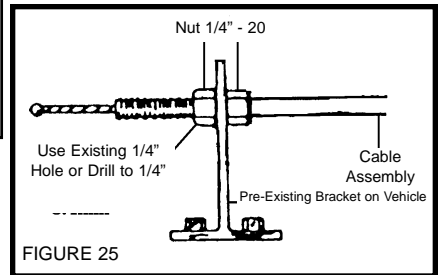

FIGURE 25

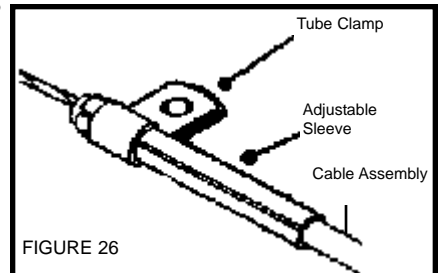

FIGURE 26

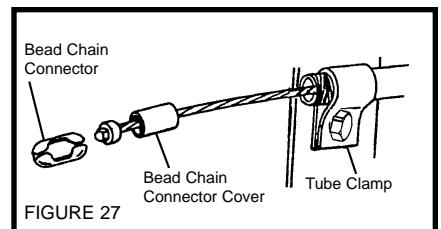
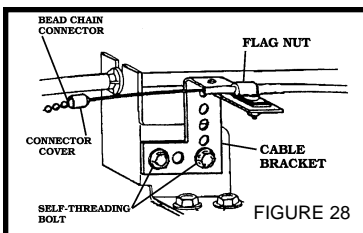

FIGURE 27



INSTALLATION PROCEDURES

WARNING:

DO NOT cut the power brake vacuum supply line. An improper connection to this line could impair the function of the vehicle's brakes.

D. VACUUM LINE INSTALLATION

Suggested Vacuum Source Locations:

1. Factory Installed Tee with removable cap
Figure 29
2. Manifold Vacuum Tree usually with an extra vacuum port with removable cap.
Figure 30
3. Existing Vacuum Canister mounted on vehicle generally on the inner fenderwell or engine bulkhead. **Figure 31**
4. Existing Manifold Vacuum Line that can be cut into (DO NOT USED BRAKE VACUUM LINE) **Figure 32**

After locating a vacuum source and making a connection, route **VACUUM HOSE** from the source and attach to the vacuum port on the **SERVO ASSEMBLY**. **DO NOT** forget to remove the protective cap prior to installing the **VACUUM HOSE**.
Figure 33

VACUUM CHECK

Run the engine at idle. Unplug the **VACUUM HOSE** from the **SERVO ASSEMBLY** and place your finger over the end of the hose. You should feel a strong suction. If not, you should find another location with stronger vacuum or add a **VACUUM RESERVOIR** (250-3417)

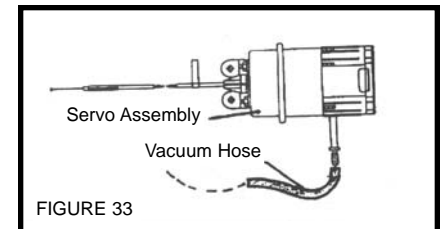
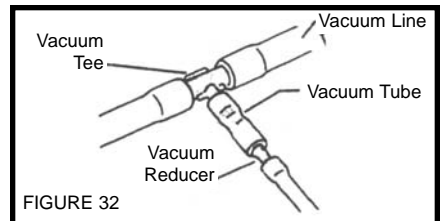
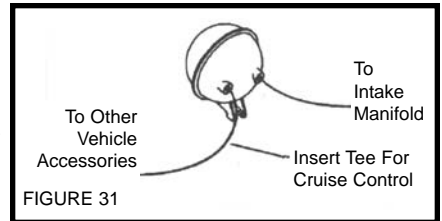
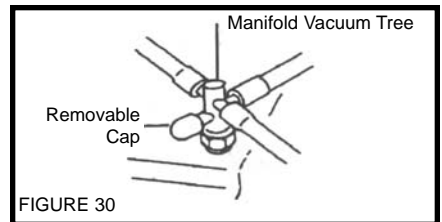
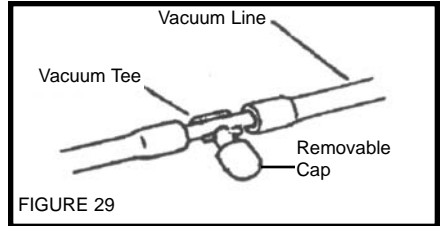
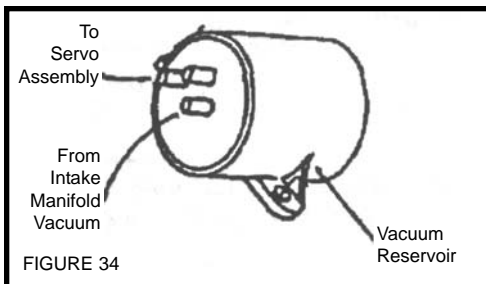

INSTALLATION PROCEDURES

E. HARNESS ASSEMBLY

1. Plug **HARNESS ASSEMBLY** into **SERVO ASSEMBLY**. Push Rubber Grommet securely into place. **Figure 35** Place cover onto the **SERVO ASSEMBLY** and securely fasten screws. **Figure 36**
2. Straighten the **HARNESS ASSEMBLY** and find the **4-pin** mating connectors. Separate the **4-pin** connectors. A small screwdriver may be needed
3. **HARNESS ASSEMBLY** needs a **3/4"** hole to pass through bulkhead. You may find one nearby, such as the speedometer cable hole or a small one you can file larger. If you find the right size hole in the right place, remove grommet. If not, drill, saw, or punch a **3/4"** hole in bulkhead. A hole a couple of inches to the left or slightly higher than the steering column is usually a good place. **Figure 37**

NOTE

Check inside before drilling, sawing, or filing so you don't damage anything.

4. From engine side, pass the **4-pin** connectors and **VIOLET** wire through hole. If you do not hook up the **Blue TACH** wire and the **Gray VSS** wire under the hood, pass them through to the inside of the vehicle, also.
5. Reattach the **4-pin** mating connectors and make the necessary wire connections. (See **Page 18** for wiring instructions)

F. SEALING BULKHEAD

Seal hole in bulkhead with **SEALING PUTTY** as shown in **Figure 38**.

G. CONTROL SWITCH INSTALLATION

If your cruise control switch is the type which clamps on the turn signal lever, requires cutting the turn signal lever, or is mounted on the instrument panel, follow the instructions packaged with it. If you have a switch which replaces the complete original equipment turn signal lever, remove the existing lever and install the cruise control switch and lever assembly as instructed in the vehicle shop service manual.

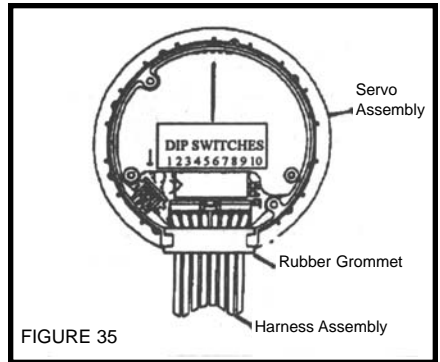

FIGURE 35

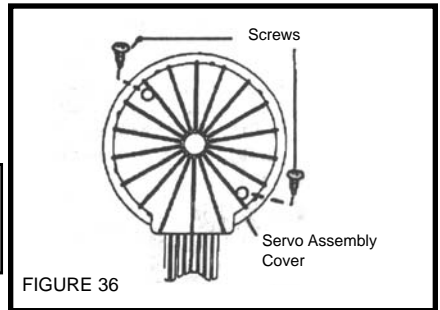

FIGURE 36

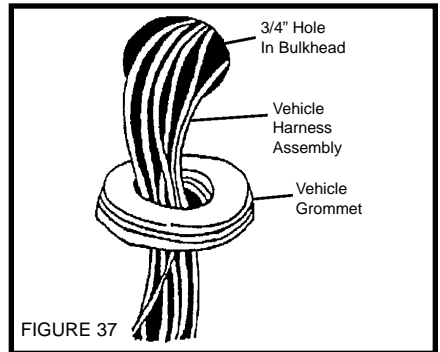

FIGURE 37

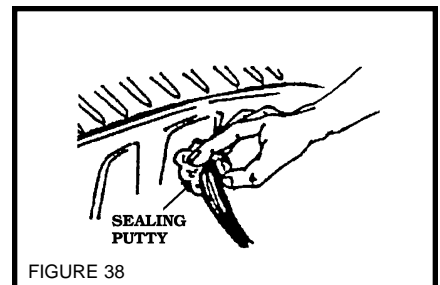

FIGURE 38

INSTALLATION PROCEDURES

CAUTION:

If a two way radio is in the vehicle or is later installed, the Servo Assembly should be located as far from the radio transceiver as practical (at least 3") and the Harness Assembly should be routed as far from the radio wires and coaxial cable as practical. The radio should be wired directly to a battery ground connection and the standing wave ratio of the antenna should be as low as possible.

H. WIRING ATTACHMENTS TO VEHICLE

To find a place to get electrical power, you will need to "ground" one lead of your test light or volt-ohm meter. Find electrical ground by turning on the ignition switch and touching one lead to a hot fused terminal at fuse panel; touch other lead to unpainted metal part of vehicle. The metal you touch, if it makes continuity, is ground. Bracket for parking brake lever is usually a good ground. Turn ignition switch off.

NOTE: Some fuse panels are behind shields which must be removed first. On other vehicles the screw that mounts the panel must be removed to get to the fuses.

CAUTION:

Before making any wiring connections, be sure to disconnect your vehicle's negative battery cable to avoid electric shock and/or damage to the vehicle's electrical system.

WIRE COLOR	FUNCTION	LOCATION
BLACK	GROUND	Vehicle ground point which is a clean unpainted metal surface. NOTE: DO NOT USE THE ENGINE AS A GROUNDING POINT. DO NOT CONNECT TO THE EXTENSION BRACKET.
BROWN	ACCESSORY POWER	Fuse panel: fuse that has +12 volts when key is ON and 0 volts when key is OFF or in the START (CRANKING) position.
RED	CONSTANT POWER	Hot side of brake switch --+12 volts
VIOLET	GROUND	Cold side of brake switch-0 resistance when brake is not pressed +12 volts or open resistance when brake is pressed.
BLUE	TACHOMETER	See Vehicle Technical Information Guide (Form#2482) or Consult Vehicle Shop Manual
GRAY	VEHICLE SPEED SENSOR	See Vehicle Technical Information Guide (Form#2482) or Consult Vehicle Shop Manual

SELF DIAGNOSTICS PROCEDURES

The **MicroCRUISE 4** is equipped with **Self Diagnostic Light Emitting Diode (LED)** located underneath the rubber grommet on top of the Cruise Module. Utilize the following **Self Diagnostic Procedure** to trouble shoot your cruise control if it does not function properly once installed.

DIAGNOSTIC LED

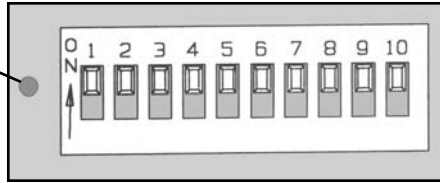

FIGURE 39

Carefully follow the procedures below to enter your cruise control into **Self Diagnostic Mode**.

Step 1: Turn the cruise control switch **OFF**.

Step 2: Turn the ignition to the **OFF** position.

Step 3: Closed Circuit Control Switch (See Page 21); Press and hold the **RESUME/ACCEL** button while you turn the ignition switch to the **ON** position without starting the engine. Now release the **RESUME/ACCEL** slide switch.

Open Circuit Control Switch (See Page 21); Turn the ignition switch to the **ON** position without starting the engine, hold the **RESUME/ACCEL** button down while you turn the cruise control switch to the **ON** position.

Step 4: The **Diagnostic LED** should be **OFF** at this time. You are now in **Self Diagnostic Mode**.

Continue to follow the procedures below to test your cruise control switch, brake switch connections and VSS Signal

Step 5: Press and Release the **SET/COAST** button. The **LED** should light each time the button is pressed and go out when it is released. If so, continue to **Step 6**, if not, go to **Step 5a**.

- Check steps to entering **Diagnostic Mode** and test again.
- Check **Programming Switch #7**. it should be **ON** for a **Normally Closed Circuit Control Switch** and **OFF** for a **Normally Open Circuit Control Switch**. (See Page 21); If set incorrectly, reset and reenter **Diagnostic Mode**.
- Check power to the **Cruise Module** if none of the diagnostic commands are functioning.
- Check **Cruise Control Switch** (See Page 21)

Step 6: Press and Release the **RESUME/ACCEL** button. The **LED** should light each time the button is pressed and go out when it is released. If so, continue to **Step 7**; if not, go to **Step 6a**.

- Check steps to entering **Diagnostic Mode** and test again.
- Check power to the **Cruise Module** if none of the diagnostic commands are functioning.
- Check **Cruise Control Switch** (See Page 21)

Step 7: You will need a second person to help you preform this test. Press and release the **Brake Pedal**. The **LED** should light each time the brake is pressed and go out when it is released. If so, continue to **Step 8**; if not, go the **Step 7a**.

- Check steps to entering **Diagnostic Mode** and test again.
- Check power to the **Red Brake Positive** wire.
- Check power to the **Cruise Module** if none of the diagnostic commands are functioning.
- Check **Brake Switch Connector** and wiring to brake switch.

SELF DIAGNOSTICS PROCEDURES

- Step 8:**
- a. Vehicles own computer as VSS source: Roll the vehicle at least **two (2) meters** forward or backward, the **LED** should flash and continue to flash at the same rate. If so, continue to **Step 9**; if not, go to **Step 8ai**.
 - i. Check steps to entering **Diagnostic Mode** and test again.
 - ii. Check **Programming Switch #10**. It should be **ON** for Square Wave Input. If set incorrectly, reset and reenter **Diagnostic Mode**.
 - iii. Some vehicles need to be pushed more than **two (2) meters**. In that case, raise **one (1)** of the vehicle's drive wheels (both drive wheels on a limited slip differential) and block the non drive wheels. Use a support stand for safety. Spin the drive wheel by hand as fast as possible. The **LED** should flash and continue to flash at the same rate. If so, continue to **Step 9**; if not, go to **Step 8aiv**.
 - iv. Either your VSS wire is incorrect or your connection is bad. Inspect your VSS connection and reenter **Self Diagnostic Mode**
 - b. **Auxiliary Speed Sensor** [Signal Generator or Magnet & Coil Pick-Up Kit (**Kit #250-4165**)] Raise **one (1)** of the vehicle drive wheels (both drive wheels on a limited slip differential) and block the non drive wheels. Use a support stand for safety. Spin the drive wheel by hand as fast as possible (You must spin the wheel at least 4.8 KPH (3 MPH) or faster in order to test an auxiliary speed signal.) The **LED** should flash and continue to flash at the same rate. If so, continue to **Step 9**; if not, go to **Step 8bi**.
 - i. Check steps to entering **Diagnostic Mode** and test again.
 - ii. Check **Programming Switch #10**. It should be **OFF** for Sine Wave Input. If set incorrectly, reset and reenter **Diagnostic Mode**.
- Step 9:** Your **MicroCruise 4** has successfully passed the **Self Diagnostic Testing Procedure**. If it still does not function, test your **TACH** signal.

WIRING DIAGRAM

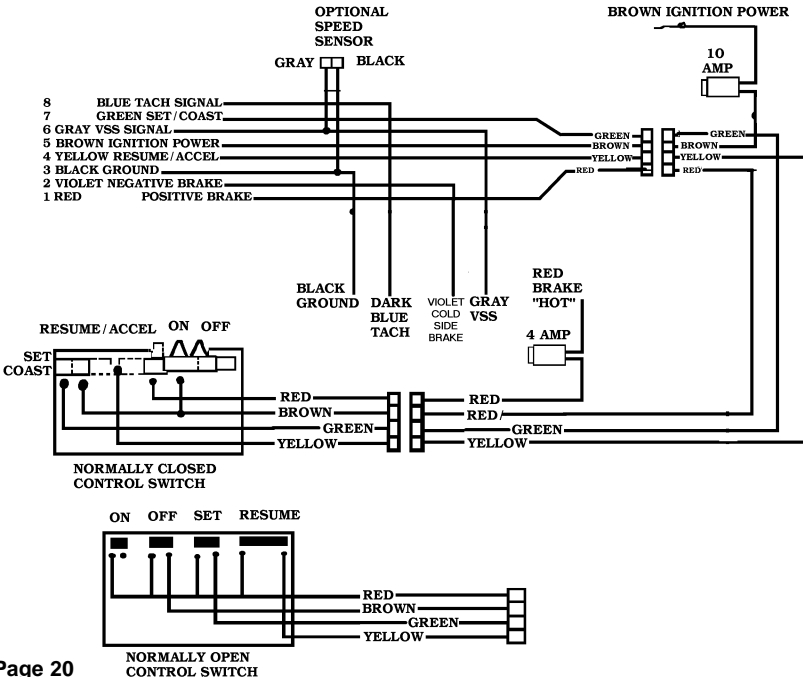

TESTING the TACH SIGNAL

If all of the previous functions are correct, check the **TACH SIGNAL**

1. Turn the **CRUISE CONTROL SWITCH** to the **OFF** position
2. Turn the ignition switch to the **OFF** position
3. Press and hold the **RESUME/ACCEL** slide switch while you turn the ignition switch to the **ON** position and start the engine. Now release the **RESUME/ACCEL** slide switch. (If you are using a 250-3592 or 250-3593 dash mount Cruise Control Switch, turn the ignition switch to the **ON** position **and start the engine**, hold the **RESUME/ACCEL** button down while you turn the **CRUISE CONTROL SWITCH** to the **ON** position.)
4. The Diagnostics LED should be flashing. Rev the engine, the LED should flash faster at higher RPM's. If not:
 - * Check steps to entering diagnostic mode and try again
 - * Connection to TACH Signal source is bad
 - * TACH Signal connection point is not correct

CONTROL SWITCH TESTS

To do the test:

1. Unplug the 8-pin connector from the Actuator Assembly.
2. Ground the test light lead and verify that the test light works by proving with a known power source.
3. **Follow Test Chart A** for a Closed Circuit Control Switch, **Test Chart B** for an Open Circuit Control Switch.

TEST CHART A (FOR CLOSED CIRCUIT CONTROL SWITCH)					
IGNITION SWITCH POSITIONS	CONTROL SWITCH POSITIONS	RED	DARK GREEN	YELLOW	BROWN
OFF	OFF	OFF	OFF	OFF	OFF
OFF	ON	ON	ON	OFF	OFF
OFF	ON press and hold RESUME/ACCEL	ON	OFF	ON	OFF
OFF	ON press and hold RESUME/ACCEL	ON	ON	ON	OFF
ON	ON	ON	ON	OFF	ON
CRANK or START	ON	ON	ON	OFF	OFF

TEST CHART B (FOR OPEN CIRCUIT CONTROL SWITCH)					
IGNITION SWITCH POSITIONS	CONTROL SWITCH POSITIONS	RED	DARK GREEN	YELLOW	BROWN
OFF	OFF	OFF	OFF	OFF	OFF
OFF	ON	ON	OFF	OFF	OFF
OFF	ON press and hold SET/COAST	ON	ON	OFF	OFF
OFF	ON press and hold SET/COAST	ON	OFF	ON	OFF
ON	ON	ON	OFF	OFF	ON
CRANK or START	ON	ON	OFF	OFF	OFF

OPERATING PROCEDURES

ROAD TESTING

Be sure to road test your **CRUISE CONTROL** after installation. If your **CRUISE CONTROL** was installed correctly, it should perform as indicated in this section. The **CRUISE CONTROL SWITCH** is used to operate the system.

TEST DRIVE

Follow the operating instructions to test drive your new **CRUISE CONTROL**. Try all functions on your **CRUISE CONTROL** to be sure it is operating correctly.

ON/OFF: The first time you use the Cruise Control you should be on a straight, paved road away from heavy traffic. Slide the **ON/OFF** switch of the **Cruise Control Switch** to the **ON** position. Nothing will happen, this simply prepares the system for use.

Remember, each time you turn OFF the ignition switch, or slide the **Cruise Control Switch** to **OFF**, you de-energize the system. To re-energize it the ignition switch must be **ON** and the slide switch must be in the **ON** position. You can leave the **Cruise Control Switch ON** all the time without damaging the system.

SET SPEED: After turning the system **ON**, wait at least three seconds before trying to set your speed. To operate the system, drive your car at a steady speed above 35 mph. Press the **SET/COAST** button, and release it. Slowly remove your foot from the accelerator. Your speed is now in the **Servo Assembly's** memory. Your driving speed should remain within 2-1/2 mph of your set speed.

ACCEL: You may increase your **SET SPEED** by using the **RESUME/ACCEL** feature. Your vehicle will accelerate as you hold the slide switch to the **RESUME/ACCEL** position. When you release the slide switch you will have a new, higher **SET SPEED**.

TAP-UP: You can also increase your speed gradually, by quickly sliding and releasing the **RESUME/ACCEL** switch. Each time you slide and release the slide switch, your speed will increase approximately one mph.

COAST: To reduce your **SET SPEED**, press and hold the **SET/COAST** button. This erases the old **SET SPEED**, and allows your vehicle to coast. Just before reaching the speed you want, release the button. This will be your new **SET SPEED**, providing you are above 35 mph.

TAP-DOWN: You can also decrease your speed gradually, by quickly pressing and releasing the **SET/COAST** button. Each time you press and release the button, your speed will decrease approximately one mph.

RESUME: When you use the brake to slow down or stop, the Cruise Control will remember your **SET SPEED**. To return to the **SET SPEED**, you need to be above 30 mph and drive to a speed within 15 mph of your **SET SPEED**. Slide the **RESUME/ACCEL** slide switch, then release it. Your vehicle will automatically accelerate to the **SET SPEED** and hold there.

When using the **RESUME** feature with a standard transmission, you must be in the correct gear for your **SET SPEED**.

After braking, the **RESUME** feature will **NOT** work if you:

- Move the slide switch to **OFF**
- Turn **OFF** the ignition

If this happens, you need to **SET SPEED** again.

DISENGAGE: You may **DISENGAGE** from your **SET SPEED** in two or three ways depending on the type of transmission (manual or automatic) you have in your car.

- Gently depress the brake pedal to activate the brake lights
- Turn the **Cruise Control Switch** to the **OFF** position
- For manual transmissions, depress the clutch (This **WILL** cause the engine to rev before disengaging)

THINGS YOU SHOULD KNOW ABOUT YOUR SPEED CONTROL

The performance of the Speed Control is dependent upon the amount of vacuum produced by the engine. The level of vacuum available from a gasoline-burning engine is determined by the condition of the engine, its size, and even by the type of emission control equipment it has. Even a small vacuum leak will reduce the system's performance, and driving at higher altitudes will have a similar effect.

Under normal conditions and with proper regulator adjustments, speed should be controlled within plus or minus 2-1/2 mph. There may be situations, however, which make it seem as if the Speed Control is not capable of functioning that accurately. Such things as an extra heavy load, a very steep hill, or a severe headwind will call for the throttle to be opened much wider than normal. A wider throttle opening will cause the vacuum to drop almost to zero, and that drop is the thing which denies the system the very strength it needs to open the throttle.

The way to handle these temporary problem situations is to momentarily bring the vehicle up to speed with the accelerator pedal - then let the Speed control take over again.

If the system does not perform as previously described, see the **Self Diagnostics** section of this manual to determine the cause.

CAUTION: Do not use Speed Control on slippery roads or in heavy traffic.

TECHNICAL SERVICE

In the event that you need technical assistance with trouble shooting, please have the following information ready when calling our **Technical Service Department 910-277-1828**. This information is important for a proper and speedy diagnosis of the problems encountered.

Model Number of Cruise Control System printed on box and manufacturers code printed on the Servo Assembly _____

Vehicle Make Model and Year: _____

Engine and Transmission: _____

Ensure that the Brake Switch wiring connections are correct.
Red wire of Wiring Harness Assembly is connected to "HOT SIDE"(color): _____

Violet wire of Wiring Harness Assembly is connected to "COLD SIDE"(color): _____

Ensure that the Brown wire is connected to an "ignition power source"

Speed Signal Source:
VSS (Vehicle Speed Signal): Gray wire connection point and wire color:

Alternative Speed Signal Source (Part #) _____

Tachometer Signal: Blue wire connection point and color _____

Servo Assembly programming switch settings:
1 2 3 4 5 6 7 8 9 10
ON
OFF

List the parts used for the throttle connection and cable anchoring. Refer to the Parts List and Parts Diagram on Pages 4-5.



ALL RIGHTS RESERVED
PRINTED IN THE USA