

**250-9000**  
**06-08 SUZUKI FORENZA/RENO**  
**07-10 CHEVROLET AVEO/WAVE**  
**09-10 PONTIAC G3**  
**CRUISE CONTROL INSTALLATION INSTRUCTIONS**

**SERVICE PART NUMBERS**

<b>ITEM</b>	<b>QTY</b>	<b>DESCRIPTION</b>	<b>PART NUMBER</b>
1	1	CONTROL MODULE	250-2711
2	1	MAIN HARNESS	250-2712
3	1	ECM HARNESS	250-2690
4	1	SWITCH	250-3742
5	1	SACK PARTS	250-2713

**CONTENTS**

<b>INSTALLATION</b>	<b>2</b>
<b>CONTROL SWITCH</b>	<b>3</b>
<b>TROUBLESHOOTING</b>	<b>5</b>

# INSTALLATION

## A. INSTALLATION PREPARATION:

- 1. DISCONNECT NEGATIVE BATTERY CABLE BEFORE INSTALLATION.** REMOVE KNEE PANEL UNDER STEERING COLUMN, THEN REMOVE **12MM AND 10MM SCREWS (4)** TO RELEASE STEEL PANEL. **FIGURE 1**
- 2.** REMOVE LOWER STEERING COLUMN COVER AND DRIVER SIDE KICK PANEL. **FIGURE 1.**
- 3. 09-10 AVEO/G3:** LOCATE THE 8-PIN CONNECTOR ON METAL BRACKET BEHIND REMOVED STEEL PANEL. CONNECT THE **WHITE WIRE** FROM ECM CRUISE HARNESS MARKED **CRUISE 1** TO THE **GRAY WIRE** OF CONNECTOR. CONNECT THE **GREEN WIRE** MARKED **CRUISE 2** TO THE **BROWN WIRE** OF CONNECTOR. **FIGURE 2.** CONNECT **BLACK WIRE** OF MAIN CRUISE HARNESS TO **BLACK WIRE** OF GROUND POINT LOCATED AT DRIVER-SIDE KICK PANEL. CONTINUE TO SWITCH INSTALLATION.

**FORENZA/RENO:** REMOVE AIR DUCT IN ENGINE COMPARTMENT TO ACCESS ECM. REMOVE RIGHT SIDE ECM CONNECTOR. **FIGURE 3.**

**08 AVEO:** REMOVE **BOTTOM** CONNECTOR AT ECM LOCATED BESIDE FUSE BOX AND BATTERY. RELEASE TOP COVER OF CONNECTOR TO ACCESS PIN LOCATION.

## B. HARNESS INSTALLATION:

- 1. CAREFULLY REMOVE CENTER SLOT CLIP AS SHOWN IN FIGURE 4.**
- 2.** USING A PRECISION TOOL, REMOVE THE GREASE IN **PIN 45.** **FIGURE 5**

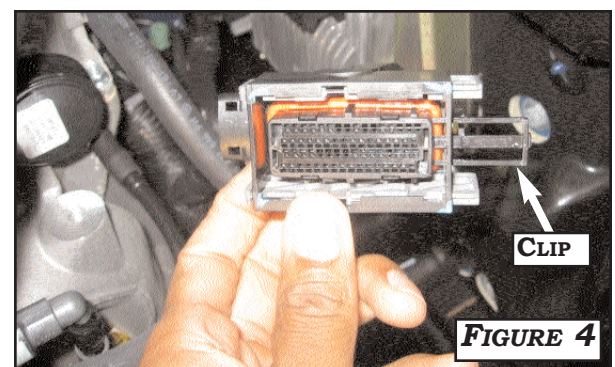
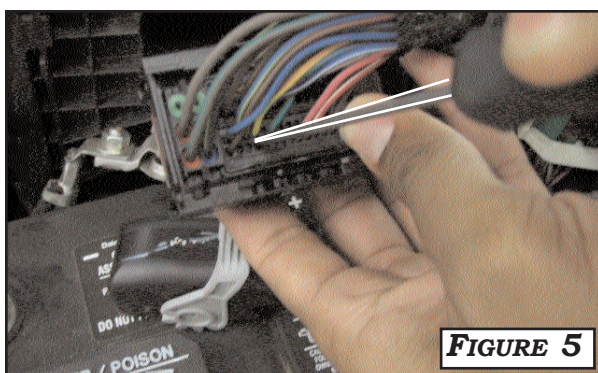
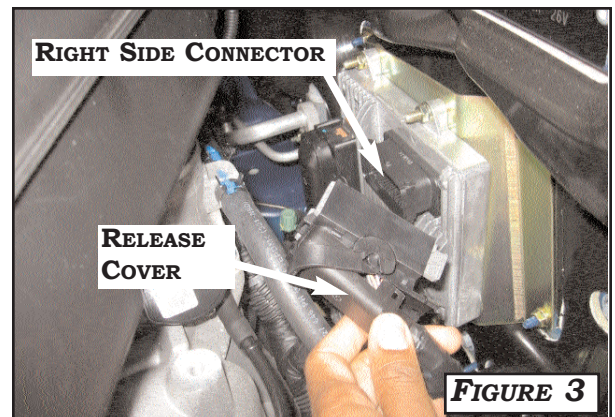
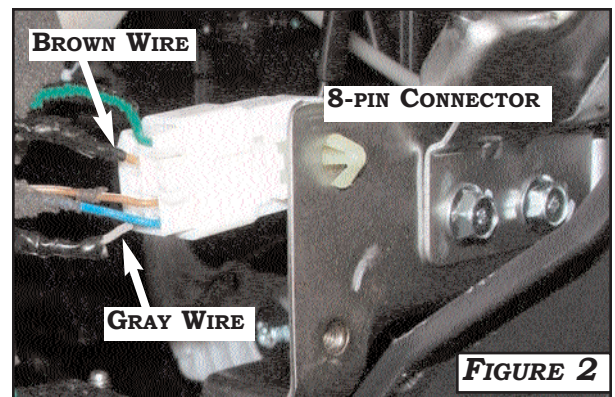
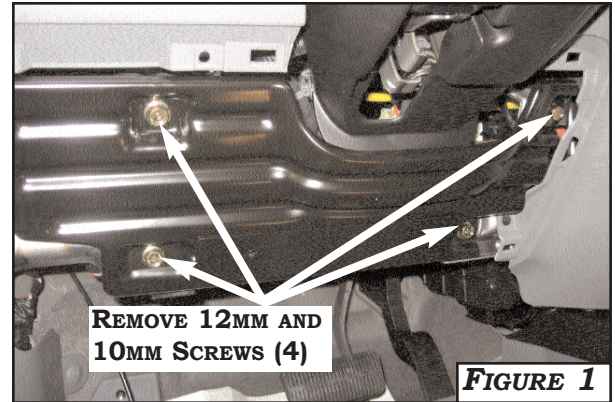

## B. HARNESS INSTALLATION (CONT):

3. INSERT **WHITE WIRE** OF ECM HARNESS TO **PIN 45** OF ECM CONNECTOR ENSURING PIN LOCKS INTO PLACE. **FIGURE 6**. REASSEMBLE CONNECTOR, INCLUDING CENTER SLOT CLIP. BE SURE TO PLACE CONNECTOR BACK ON ECM SECURELY.

**NOTE: SOME 08 CHEVY AVEOS WILL HAVE GREEN/WHITE OR GRAY WIRE IN PIN 45. CONNECT WHITE WIRE TO EXISTING WIRE.**

4. ROUTE WIRE THROUGH ACCESS GROMMET AS SHOWN IN **FIGURE 7**.

5. CONNECT **WHITE WIRE** OF ECM HARNESS TO **WHITE WIRE** MARKED **CRUISE 1** OF MAIN CRUISE HARNESS. CONNECT **+12V RED WIRE** FROM MAIN CRUISE HARNESS TO **PINK WIRE** FURTHEST TO LEFT BEHIND FUSE PANEL OR OTHER +12V IGNITION POWER SOURCE. **FIGURE 8**

6. CONNECT **BLACK WIRE** OF MAIN CRUISE HARNESS TO **BLACK WIRE** OF GROUND POINT LOCATED AT DRIVER-SIDE KICK PANEL. **FIGURE 9**. CONNECT **GREEN WIRE** MARKED **CRUISE 2** OF MAIN CRUISE HARNESS TO SAME **BLACK WIRE** GROUND POINT.

## C. SWITCH INSTALLATION:

1. ALIGN TAPE MEASURE ON SHROUD AND MARK HOLE AS SHOWN IN **FIGURE 10**. USE THE **LEVER WEDGE** AS AN ANGLE TEMPLATE TO DRILL **9.5MM OR 3/8"** HOLE IN LOWER SHROUD.

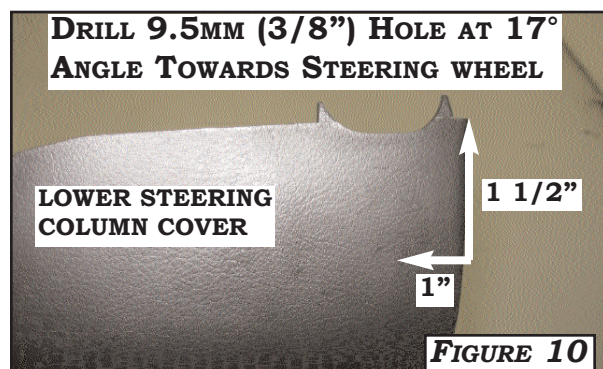
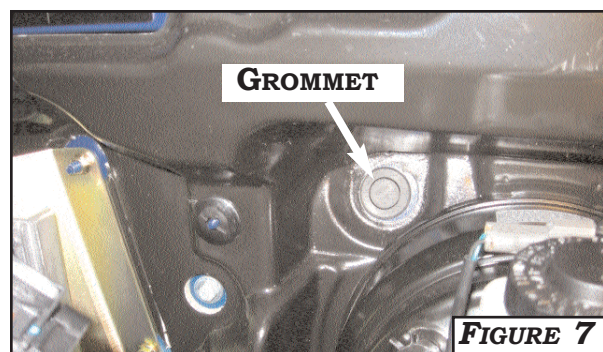
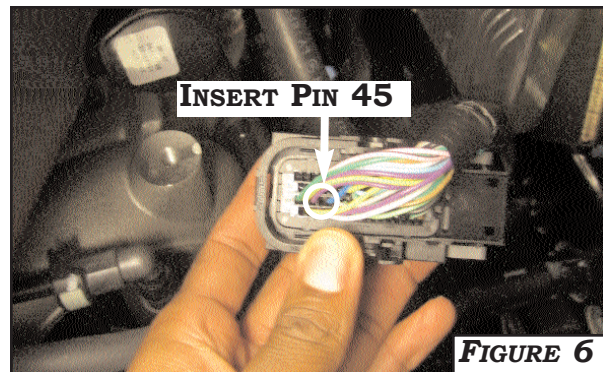

## C. SWITCH INSTALLATION (CONT):

2. POSITION THE LOCKWASHERS AS SHOWN IN **FIGURE 11**. START NUT AND POSITION THE LETTERING FOR DRIVER'S BEST VIEW. FULLY SECURE NUT AT **2.5-2.8Nm**. **DO NOT OVERTIGHTEN**.
3. INSTALL 4 PIN CONNECTOR ON **RED, BROWN, GREEN, AND YELLOW** SWITCH WIRES. INSTALL 2 PIN CONNECTOR ON **BLUE** AND **BLACK** WIRES OF SWITCH HARNESS SUCH THAT, WHEN CONNECTED TO MAIN CRUISE HARNESS, **BLACK** GOES TO **BLACK** AND **BLUE** GOES TO **RED**. **FIGURE 12**.
4. CONNECT SWITCH HARNESS TO MAIN CRUISE HARNESS. VERIFY THAT ALL COLORS MATCH WITH THE EXCEPTION OF THE **BLUE** TO **RED** WIRE CONNECTION ON THE 2 PIN CONNECTOR. CONNECT MAIN CRUISE HARNESS TO CRUISE CONTROL MODULE.

## D. REASSEMBLY:

1. REINSTALL DRIVER SIDE KICK PANEL, LOWER STEERING COLUMN COVER, STEEL COVER, AND KNEE PANEL UNDER STEERING COLUMN.

2. SECURE ALL WIRES WITH WIRE TIES.

3. RECONNECT NEGATIVE BATTERY CABLE.

## E. TESTING:

1. TEST CRUISE FUNCTIONS IN ACCORDANCE WITH OPERATING INSTRUCTIONS.

**IMPORTANT: VERIFY CRUISE DISENGAGES WHEN VEHICLE IS PUT IN NEUTRAL OR BRAKE IS DEPRESSED.**

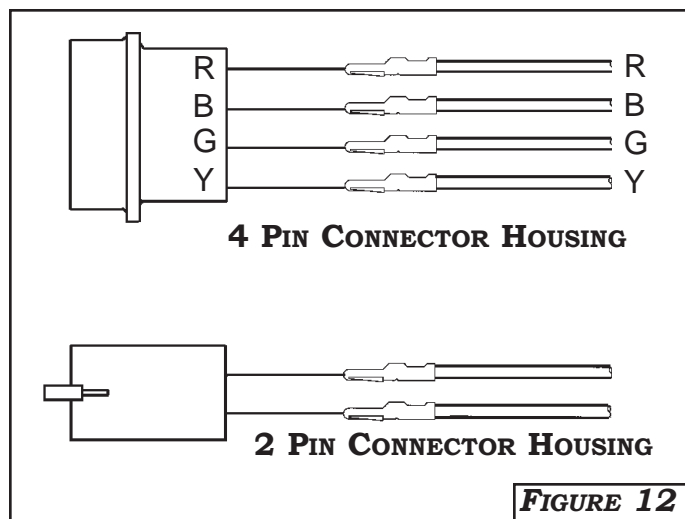
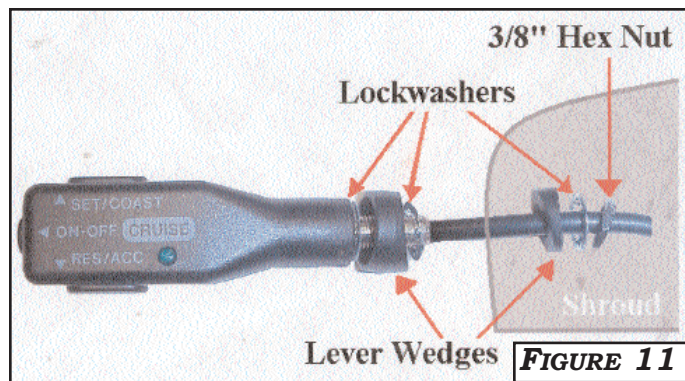

## TROUBLESHOOTING

1. Check black and green wires with meter for ground no higher than 3 ohms of resistance.
2. Check Red wire for ignition 12 volts.
3. With everything connected, check White wire voltages at the control module in harness:

Off: 5 volts on White wire from the ECM

On: 3.7 volts on White wire.

On with "Set" pressed: 2.2 volts on White wire.

On with "Resume" pressed: 2.8 volts on White wire.



ROSTRA.COM