

REARSIGHT CAMERA SYSTEM

250-8118

ULTRA and FIN Camera Applications Installation Instructions

Parts Identification	Page 1
System Layout	Page 2
Installation	Page 3
Testing	Page 5
Reassembly	Page 5
Installation Tips	Page 5

 **CAUTION:** To minimize risk of injury from contact with the monitor during an accident, always wear your seat belt.

Parts Identification

Item	Qty.	Part Number	Description
1	1	250-8118	RearSight Monitor
2A	1	250-8096	Rear Camera Assembly (FIN)
2B	1	250-8098	Rear Camera Assembly (ULTRA)
3	1	250-8580	Camera RCA and Power Harness
4	1	250-8579	30-foot Camera Extension Cable
5	1	250-8509	Sack Parts: Tie Straps, T-taps, Sealing Putty



System Layout

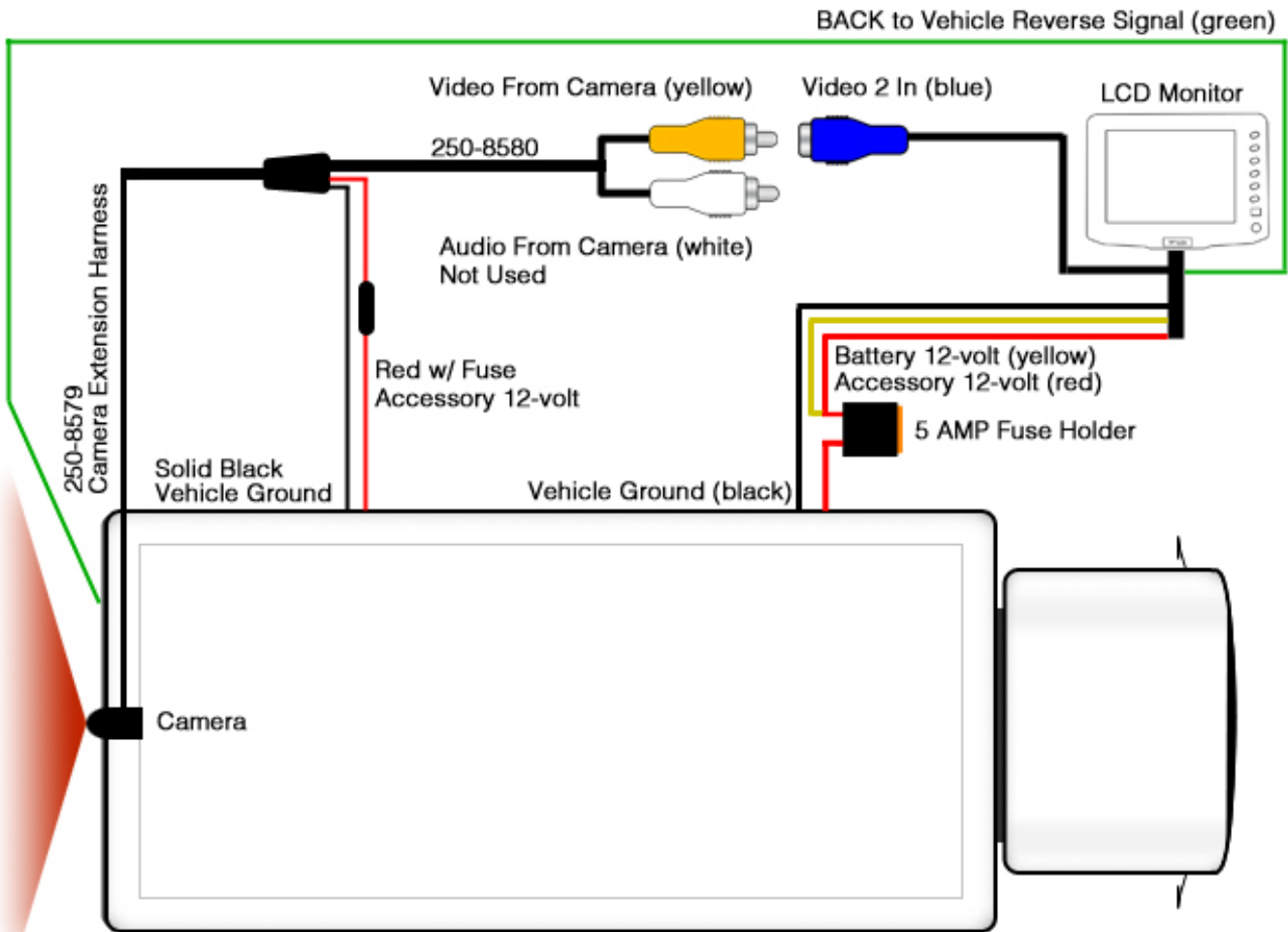

Vehicle Preparation

Before beginning your installation, familiarize yourself with the installation instructions and the RearSight camera system components.

To ensure your safety, **(A)** apply the emergency brake and **(B)** read this entire manual before beginning.



CAUTION: It is advisable to disconnect the negative battery cable for 3 minutes before beginning installation, to avoid unintended air bag deployment. Note and record any anti-theft radio codes prior to disconnecting.

Installation

Harness Connections

Route harnesses to be joined with Video 2 In (blue) RCA connection of LCD monitor (Video 2 In allows reverse override to function). Use provided wire ties to secure wiring harnesses away from moving parts and sharp edges of the vehicle.

- RCA Yellow from camera harness 250-8580 to Video 2 In (blue) of LCD monitor.
- RCA White from camera harness 250-8580 not used.
- Solid Black wires from camera harness 250-8580 and LCD monitor to chassis ground.
- Red wire from camera harness 250-8580, red ACC, and yellow BAT of LCD monitor to accessory 12-volt power.
- Green BACK wire from LCD monitor to vehicle 12-volt reverse signal.

Note: Video 1, 2, and 3 In (yellow, white, and red) of LCD monitor are not used in this application, but are available for use with any device that provides video via a standard RCA connection.

Monitor Mounting (with attached stem)

- Remove existing rearview mirror from vehicle.
- Mount RearSight monitor to attached windshield lug and tighten screw.
- Route camera extension harness to the rear of the vehicle.
- Secure harnesses with wire ties.



Monitor Mounting (with included dash mount)

- Before removing adhesive backing, form pedestal base to fit the contour of the dashboard where the monitor is to be installed.
- Once dry fitment is complete, attach the LCD monitor to the pedestal mount to verify placement and security of fasteners that connect the monitor to the mount.
- Thoroughly clean desired mounting space on dashboard to ensure proper adhesion of the mounting tape.



Note: By failing to properly form base tabs, the pedestal mount will not secure to the dashboard.

Camera Mounting

When choosing a mounting location for your camera, choose a location that meets the following requirements:

- The camera is mounted in a manner that provides a clear view of the area behind the vehicle that needs to be visualized in the monitor. When possible, this should include a portion of the rear of the vehicle so as to provide a point of reference for the driver.
- When possible, the camera should be mounted in an area of the vehicle that protects it from damage due to general vehicle use where it will not make contact with shipping bay doors, building awnings, or be subject to movement such as on the bed of a dump truck.

- When possible, avoid mounting the camera too low on a vehicle where the lens will be subject to being covered with road dirt, mud, or exhaust gases.
- Use supplied bracket as a template for mounting hole locations.
- Assemble camera as shown in included instructions.



Testing and Reassembly

Testing

1. Reconnect the negative battery cable and torque to 3 ft-lbs.
2. Re-enter any theft deterrent information (if applicable).
3. Turn the ignition switch to ON. Press the MENU button to switch from VIDEO 1 to VIDEO 2. Verify that the RearSight monitor is on and the camera's picture appears. Press the POWER button. Place the vehicle in reverse gear. Verify that the camera's picture appears.

Note: If there is no picture present, re-check all harness connections.

Reassembly

1. Reinstall all trim pieces taking special care to ensure harnesses and wiring connections are properly secured.
2. Make sure no harnesses are bent or pinched by trim pieces.
3. Reconnect all disconnected bulbs and check for function.

Installation Tips

- Confirm proper cable extension connector orientation and always verify proper ends are routed in correct direction.
- It is a good idea to dry-fit all pieces in this kit before permanently attaching them to ensure proper orientation and operation before beginning installation for familiarization with components.
- Always treat any metal exposed during installation with a rust preventative compound to prevent system failure due to rust and/or corrosion.
- Always seal any holes drilled with the provided sealing putty to prevent water infiltration through unprotected areas.
- Confirm integrity of mechanical and electrical connections before moving to next installation sequence.