

PARKPILOT

ULTRASONIC PARKING ASSIST SYSTEM



CONTENTS

| | |
|----------------------------|----------|
| Parts List..... | 2 |
| Installation..... | 3 |
| System Testing..... | 6 |
| Appendix..... | 8 |

PARTS LIST

| ITEM | QUANTITY | PART NUMBER | DESCRIPTION |
|------|------------|--------------|--|
| 1 | 2 OR 4 | 250-2990F(A) | ULTRASONIC SENSOR |
| 2 | 1 | 250-2992 | CONTROL MODULE |
| 3 | 1 | 250-2993 | ALARM UNIT |
| 4 | 1 | 250-2994 | HARDWARE PACKAGE: CABLE TIES, SCOTCH LOCKS, TAPE |
| 5 | 1 | 250-2995 | POWER HARNESS |
| 6 | (OPTIONAL) | 250-2996 | TRAILER RECOGNITION MODULE |

DIAGRAM A

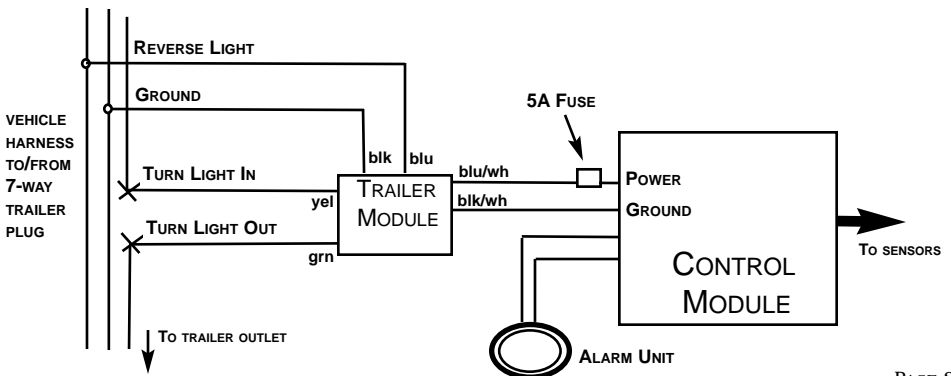
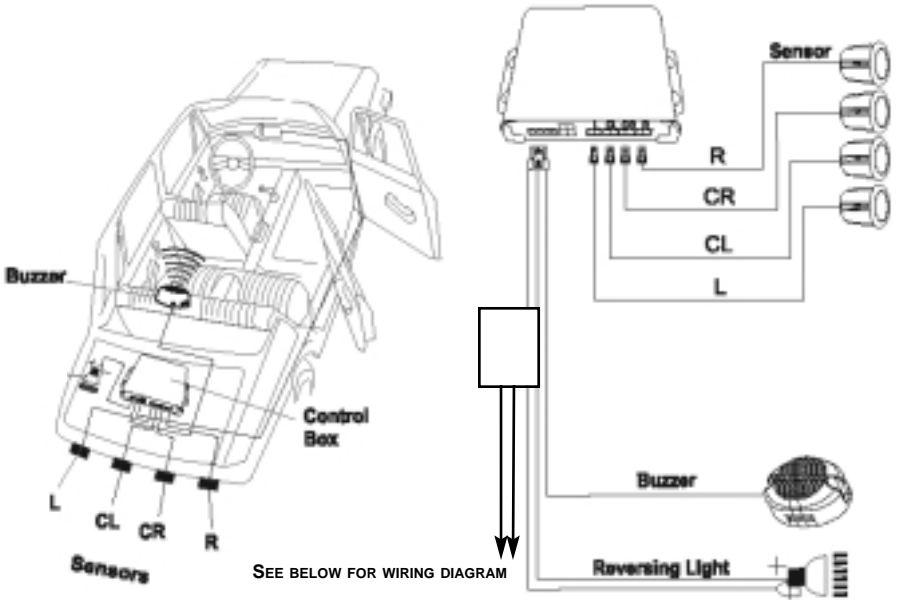

BEFORE YOU START

BEFORE BEGINNING INSTALLATION, FAMILIARIZE YOURSELF WITH THE INSTALLATION INSTRUCTIONS AND THE PARKPILOT SYSTEM COMPONENTS.

TO ENSURE YOUR SAFETY:

- A) MAKE SURE YOUR VEHICLE IS IN "PARK".
- B) APPLY THE EMERGENCY BRAKE.
- C) PLACE WHEEL BLOCKS BEHIND THE REAR TIRES.
- D) IF YOU LIFT THE VEHICLE, ENSURE THAT YOU USE JACK STANDS AND FOLLOW THE VEHICLE'S MANUFACTURER LIFTING INSTRUCTIONS.
- E) READ THIS MANUAL BEFORE STARTING.

INSTALLATION

TO INSTALL THE PARKPILOT™ SYSTEM, FOLLOW THESE STEPS:

STEP 1: SENSOR LOCATION.

STEP 2: MOUNT SENSORS.

STEP 3: MOUNT CONTROL MODULE AND TRAILER MODULE (OPTIONAL).

STEP 4: MOUNT AUDIO ALARM UNIT.

STEP 5: TEST THE SYSTEM.

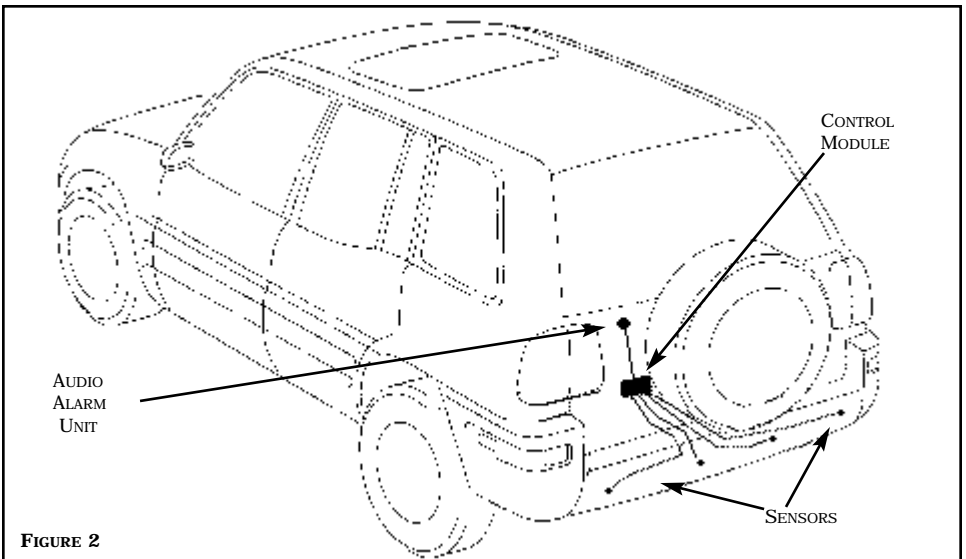
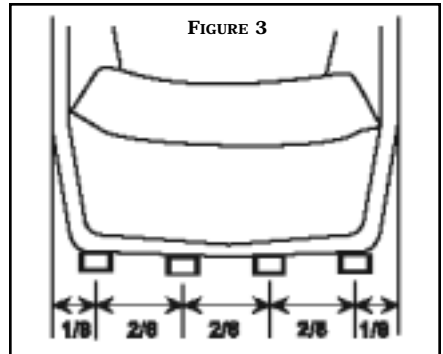

FIGURE 2

INSTALLATION

STEP 1: SENSOR LOCATION

1. THE PARKPILOT SENSORS ARE DESIGNED TO MOUNT FLUSH IN A BUMPER FASCIA. FOR 4 SENSOR SYSTEMS, MEASURE THE WIDTH OF THE BUMPER AND MARK LOCATIONS AT $1/8$ AND $3/8$ DISTANCE IN FROM EACH END AS SHOWN IN **FIGURE 3**. FOR 2 SENSOR SYSTEMS, PLACE ONE SENSOR AT $1/4$ DISTANCE FROM EACH END. THE IDEAL LOCATION WILL BE A FLAT SURFACE THAT IS PERPENDICULAR TO THE GROUND, AND 18"-22" OFF THE GROUND. FOR VERY ANGLED BUMPERS WHERE A PERPENDICULAR SURFACE IS UNAVAILABLE, COMPENSATE BY USING THE SPECIAL ANGLED-BEZEL SENSOR, PART # 250-2990A. **NOTE: MAKE SURE THERE IS ROOM BEHIND THE FASCIA FOR THE BODY OF THE SENSOR AND ITS WIRE HARNESS PRIOR TO DRILLING.**



2. DRILL A 22MM HOLE AT EACH MARK USING A HOLE SAW OR EQUIVALENT TOOL. BE SURE TO HOLD THE DRILL STEADY AND LEVEL. CAREFULLY USE A FINE METAL FILE TO REMOVE ANY BURRS OF PLASTIC IN THE HOLES. **FIGURE 4**

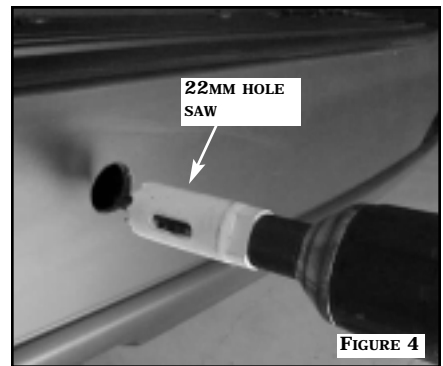

STEP 2: SENSOR MOUNTING

1. LOCATE THE ID TAGS ON THE SENSOR HARNESSSES THAT CORRESPOND TO THEIR BUMPER LOCATION. THEY WILL BE MARKED "L" (LEFT), "CL" (CENTER LEFT), "CR" (CENTER RIGHT), AND "R" (RIGHT). REFER TO **DIAGRAM A** ON **PAGE 2** FOR LOCATION.

2. FEED THE SENSOR HARNESS THROUGH THE HOLE UNTIL IT'S ACCESSIBLE FROM THE INSIDE OF THE BUMPER. ROUTE THE HARNESS AWAY FROM ANY SHARP EDGES AND PULL IT UNTIL THE SENSOR IS AT THE FASCIA. TURN THE SENSOR SO THAT MOUNTING TAB WITH THE ARROW ON IT IS FACING THE TOP OF THE VEHICLE AS SHOWN IN **FIGURE 5**. PRESS THE SENSOR FIRMLY INTO THE FASCIA, MAKING SURE THE SENSOR SNAPS INTO PLACE AND FITS SNUGLY. **FIGURE 6**

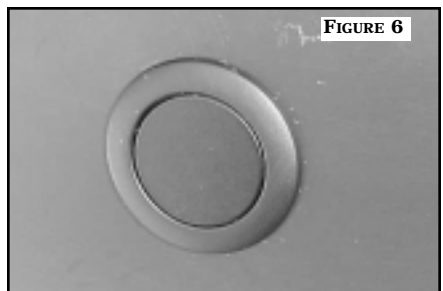
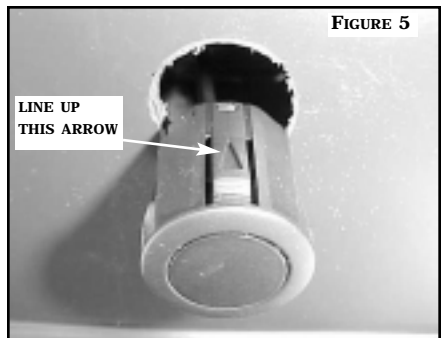

INSTALLATION

STEP 3A: POWER CONNECTIONS WHEN USING A TRAILER MODULE (OPTIONAL)

NOTE: IF NOT USING A TRAILER MODULE, SKIP TO STEP 3B.

1. LOCATE THE VEHICLE HARNESS LEADING TO THE 4- OR 7-POLE TRAILER PLUG CONNECTOR. AN EXAMPLE IS SHOWN IN **FIGURE 7**. USING THE SUPPLIED BLUE SCOTCH LOCK CONNECTORS, CONNECT THE **BLUE POWER WIRE** OF THE PARKPILOT TRAILER MODULE TO THE HARNESS' +12V REVERSE LIGHT WIRE. *NOTE: FOR 7-POLE CONNECTORS, REVERSE WILL BE THE CENTER TERMINAL. FOR 4-POLE TRAILER CONNECTORS, MAKE THE CONNECTION FOR REVERSE LIGHT POWER BEHIND THE TAIL-LIGHT.* CONNECT THE **BLACK GROUND WIRE** OF THE PARKPILOT TRAILER MODULE TO THE GROUND WIRE OF THE TRAILER CONNECTOR HARNESS OR TO A CHASSIS GROUND.
2. CUT EITHER THE LEFT OR RIGHT STOP/TURN WIRES OF THE TRAILER HARNESS INTO TWO PIECES AT LEAST 3" FROM ANY CONNECTORS AS SHOWN IN **FIGURE 8**. USING THE SUPPLIED SCOTCH LOCKS OR BUTT SPLICES, SPLICE THE VEHICLE SIDE OF THE WIRE (THE END THAT LEADS BACK INTO THE VEHICLE) TO THE **YELLOW WIRE** OF THE PARKPILOT TRAILER MODULE. SPLICE THE TRAILER END (THE END LEADING TO THE 4- OR 7-POLE TRAILER PLUG CONNECTOR) TO THE **GREEN WIRE** OF THE PARKPILOT TRAILER MODULE.
3. ROUTE THE RED AND BLACK WIRES OF THE PARKPILOT POWER HARNESS OR CONTROL MODULE TO THE UNDERSIDE OF THE VEHICLE. CONNECT THE **BLUE/WHITE OUTPUT POWER WIRE** OF THE PARKPILOT TRAILER MODULE TO THE **RED POWER WIRE** OF THE PARKPILOT POWER HARNESS. CONNECT THE **BLACK/WHITE OUTPUT GROUND WIRE** OF THE PARKPILOT TRAILER MODULE TO THE **BLACK GROUND WIRE** OF THE PARKPILOT POWER HARNESS. SECURE ALL WIRES WITH WIRE TIES.
4. SKIP TO STEP 3B, ITEM 2.

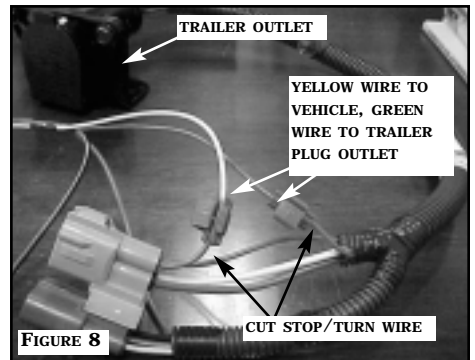
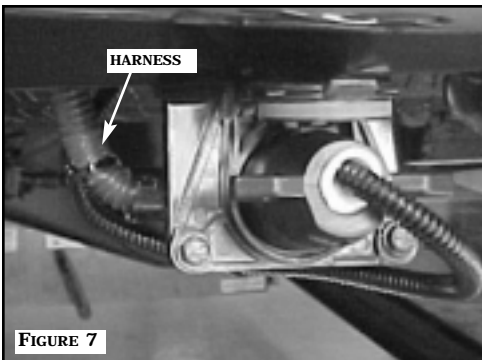

INSTALLATION

STEP 3B: POWER CONNECTIONS AND CONTROL MODULE MOUNTING

1. CONNECT THE WHITE 4-PIN CONNECTOR FROM THE PARKPILOT POWER HARNESS TO THE CONTROL MODULE (ECU). USING THE SUPPLIED BLUE SCOTCH LOCK CONNECTORS, CONNECT THE **RED POWER WIRE** OF THE PARKPILOT POWER HARNESS TO THE +12V REVERSE LIGHT. CONNECT THE **BLACK GROUND WIRE** OF THE PARKPILOT POWER HARNESS TO THE REVERSE LIGHT GROUND OR A CHASSIS GROUND. CONNECT THE TWO OR FOUR SENSOR HARNESSES TO THE CORRESPONDING SLOTS ON THE CONTROL MODULE.

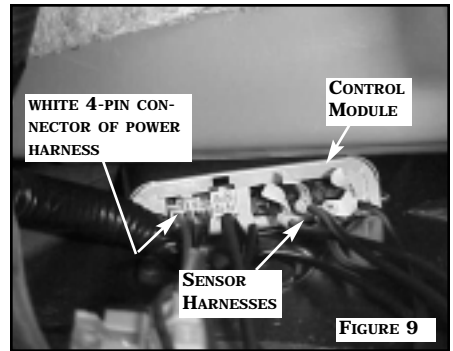

2. USING THE SUPPLIED VELCRO PAD, MOUNT THE ECU BEHIND A TRIM PANEL IN THE TRUNK OR CARGO AREA AS SHOWN IN **FIGURE 9**. THE ECU MUST BE MOUNTED INSIDE THE VEHICLE AWAY FROM AREAS PRONE TO MOISTURE. ALSO, MAKE SURE THE IN-LINE FUSE HOLDER IS ON THE INSIDE OF THE VEHICLE. SECURE EXCESS WIRE WITH WIRE TIES.

STEP 4: ALARM UNIT MOUNTING

1. CONNECT THE WHITE 2-PIN CONNECTOR FROM THE PARKPILOT POWER HARNESS TO THE 2-PIN CONNECTOR OF THE ALARM UNIT. THE "HI/LO/OFF" SWITCH ON THE UNIT IS PRE-SET TO THE "HI" SETTING. VERIFY THIS AND MOUNT THE ALARM UNIT TO ANY FLAT SURFACE BEHIND A TRIM PANEL AS SHOWN IN **FIGURE 10**.



SYSTEM TESTING

TURN THE IGNITION TO THE "ON" POSITION, ENGAGE THE EMERGENCY BRAKE, AND PUT THE VEHICLE INTO REVERSE. THE ALARM UNIT WILL ALERT TWO QUICK BEEPS TO INDICATE THAT THE SYSTEM IS ACTIVE. REFER TO **FIGURE 13** FOR DETECTION PATTERN. AVERAGE DISTANCES ARE AS FOLLOWS: ZONE 1 (SLOW BEEPING) FROM 60" TO 35", ZONE 2 (FAST BEEPING) FROM 35" TO 18", AND ZONE 3 (SOLID TONE) IS 18" AND LESS.

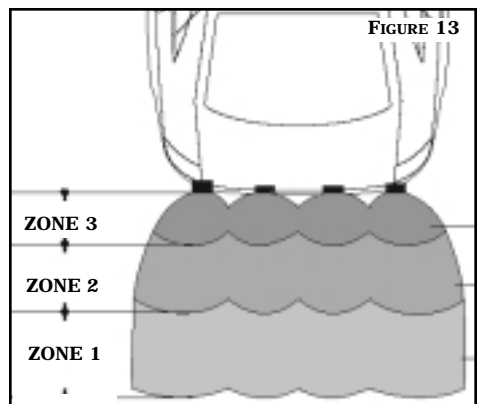

36-MONTH/36,000-MILE LIMITED WARRANTY

ROSTRA PRECISION CONTROLS, INC. (THE COMPANY), WARRANTS TO THE ORIGINAL RETAIL PURCHASER OF THIS PRODUCT THAT SHOULD THIS PRODUCT OR ANY PART THEREOF, UNDER NORMAL USE AND CONDITIONS, BE PROVEN TO HAVE DEFECTIVE MATERIAL OR WORKMANSHIP WITHIN 36 MONTHS OR 36,000 MILES OF THE ORIGINAL PURCHASE, WHICHEVER FIRST OCCURS. SUCH DEFECTS WILL BE REPAIRED OR REPLACED (AT THE COMPANY 'S OPTION) WITHOUT CHARGE FOR THE PARTS. THIS WARRANTY DOES NOT APPLY TO BATTERIES OR NORMAL WEAR AND TEAR ASSOCIATED WITH THE PRODUCT.

TO OBTAIN REPAIR OR REPLACEMENT WITHIN THE TERMS OF THIS WARRANTY, THE PRODUCT IS TO BE DELIVERED, TRANSPORTATION PREPAID, WITH PROOF OF WARRANTY COVERAGE (E.G., DATED BILL OF SALE) AND SPECIFICATION OF DEFECTS, TO THE INSTALLING DEALER AND/OR RETAILER.

THIS WARRANTY DOES NOT COVER COSTS INCURRED FOR THE REMOVAL OR REINSTALLATION OF THE PRODUCT, AND/OR RELATED COMPONENTS, AND/OR DAMAGE TO THE VEHICLE 'S ELECTRICAL SYSTEM OR COMPONENTS.

THIS WARRANTY DOES NOT APPLY TO ANY PRODUCT OR PART THEREOF WHICH, IN THE OPINION OF THE COMPANY, HAS BEEN DAMAGED THROUGH ALTERATION, IMPROPER INSTALLATION, MISUSE, NEGLIGENCE, ACCIDENT, OR CUSTOMER ABUSE.

THIS WARRANTY IS IN LIEU OF ALL OTHER EXPRESSED WARRANTIES OR LIABILITIES. **ANY IMPLIED WARRANTIES, INCLUDING ANY IMPLIED WARRANTY OF MERCHANTABILITY, SHALL BE LIMITED TO THE DURATION OF THIS WRITTEN WARRANTY. ANY ACTION FOR BREACH OF ANY WARRANTY HEREUNDER, INCLUDING ANY IMPLIED WARRANTY OF MERCHANTABILITY, MUST BE BROUGHT WITHIN A PERIOD OF 42 MONTHS FROM DATE OF ORIGINAL PURCHASE. IN NO CASE SHALL THE COMPANY BE LIABLE FOR ANY CONSEQUENTIAL OR INCIDENTAL DAMAGES FOR BREACH OF THIS OR ANY OTHER WARRANTY, EXPRESSED OR IMPLIED, WHATSOEVER.** NO PERSON OR REPRESENTATIVE IS AUTHORIZED TO ASSUME FOR THE COMPANY ANY LIABILITY OTHER THAN EXPRESSED HEREIN IN CONNECTION WITH THE SALE OF THIS PRODUCT.

THE EXTENT OF THE COMPANY 'S LIABILITY UNDER THIS WARRANTY IS LIMITED TO THE REPAIR OR REPLACEMENT PROVIDED ABOVE, AND IN NO EVENT SHALL THE COMPANY 'S LIABILITY EXCEED THE PURCHASE PRICE PAID BY THE PURCHASER FOR THE PRODUCT. SOME STATES DO NOT ALLOW LIMITATIONS ON HOW LONG AN IMPLIED WARRANTY LASTS OR THE EXCLUSION OR LIMITATION OF INCIDENTAL OR CONSEQUENTIAL DAMAGE, SO THE ABOVE LIMITATIONS OR EXCLUSIONS MAY NOT APPLY TO YOU. THIS WARRANTY GIVES YOU SPECIFIC LEGAL RIGHTS, AND YOU MAY ALSO HAVE OTHER RIGHTS WHICH VARY FROM STATE TO STATE.

CUSTOMER 'S

NAME: _____

ADDRESS: _____

CITY: _____ STATE: _____ ZIP: _____

DEALER

NAME: _____

DEALER

ADDRESS: _____

CITY: _____ STATE: _____ ZIP: _____

DATE PURCHASED: _____ DATE INSTALLED: _____

MAKE & YEAR OF CAR: _____

MILEAGE AT INSTALLATION: _____

APPENDIX: UNDER BUMPER SENSOR INSTALLATION

THE PARKPILOT UNDER BUMPER SYSTEM IS DESIGNED FOR VEHICLES WITH METAL BUMPERS OR WHEN DRILLING HOLES IN THE REAR FASCIA IS NOT POSSIBLE. THIS SYSTEM IS SEALED AND WEATHERPROOFED SO THAT THE CONTROL MODULE CAN BE MOUNTED OUTSIDE THE VEHICLE, SUCH AS UNDER THE BED OF A PICKUP TRUCK.

1. MEASURE THE WIDTH OF THE BUMPER AND MARK LOCATIONS AT $1/4$ DISTANCE IN FROM EACH END AS SHOWN IN **FIGURE 1**. THE IDEAL LOCATION WILL BE A FLAT SURFACE THAT IS PARALLEL TO THE GROUND, AND 18"-22" OFF THE GROUND. FOR APPLICATIONS WHERE THE MOUNTING SURFACE POINTS TOWARD OR IS TOO LOW TO THE GROUND, COMPENSATE BY USING THE ANGLED RUBBER SHIMS INCLUDED IN THE KIT AS SHOWN IN **FIGURE 2**. MARK THE LOCATIONS OF THE MOUNTING HOLES ON THE BOTTOM OF THE BUMPER.

2. DRILL $3/16$ " HOLES AT EACH MARK. BE SURE TO HOLD THE DRILL STEADY AND LEVEL. USE THE SUPPLIED PHILLIPS HEAD BOLTS AND NUTS TO MOUNT THE SENSORS TO THE BUMPER. **FIGURE 3** CONNECT THE SENSORS TO THE CONTROL MODULE VIA THE EXTENSION HARNESSSES.

