

CRUISE KIT NUMBERS

**P/N 250-9500
2007-2008 FORD F150**

**P/N 250-9501
2008-2010 FORD F250/F350
2008-2010 FORD E250/E350**

**P/N 250-9502
2010-2011 MAZDA 3**

**P/N 250-9503
2010 MAZDA 6**

**P/N 250-9504
2007-2010 VERSA W/O ABS**

Kit Number	Cruise Module	Pedal Interface Harness	Diagnostic Harness	Switch Harness	Main Harness	Control Switch
250-9500	250-2775	250-2780	250-2785	250-2760	250-2759	250-3742
250-9501	250-2776	250-2780	250-2785	250-2760	250-2759	250-3742
250-9502	250-2777	250-2781	250-2783	250-2760	250-2759	250-3742
250-9503	250-2778	250-2771	250-2783	250-2760	250-2759	250-3742
250-9504	250-2787	250-2788	250-2785	250-2760	250-2759	250-3742



ALL NON PLUG AND PLAY CONNECTIONS MUST BE SOLDERED. FAILURE TO COMPLY WITH THIS REQUIREMENT WILL VOID WARRANTY.



INSTALLATION MUST BE PERFORMED BY A COMPETENT PROFESSIONAL. ALL CONNECTIONS AND CIRCUITS MUST BE TESTED WITH A MULTI METER.



WARNING: DO NOT USE HAND-HELD 2-WAY TRANSCEIVERS INSIDE YOUR VEHICLE WHILE DRIVING.

WHEN TRANSMITTING FROM INSIDE THE CAR, 2-WAY RADIOS THAT OPERATE IN THE 25MHZ-700MHZ FREQUENCY RANGE WITH MORE THAN 2.0 WATTS OF POWER CAN PRODUCE ELECTROMAGNETIC INTERFERENCE THAT COULD INTERFERE WITH THE OPERATION OF CRUISE AND THROTTLE CONTROLS RESULTING IN VEHICLE "LIMP MODE". USE OF CELLULAR PHONES WILL NOT INTERFERE WITH THESE CONTROLS.

Installation Procedure

NOTE: Read this procedure before beginning work on the vehicle. Follow this procedure carefully to ensure proper installation.

NOTE: Failure to solder all spliced connections voids the warranty of this cruise control product.

NOTE: Due to the possibility of vehicle variation, even within a make/model/year, we require that you test cruise control for proper operation BEFORE making irreversible changes to the interior paneling (For example: drilling steering column shroud, or modifications to the OBDII connector mount). Rostra Precision Controls will not replace modified interior paneling.

Kit components

Kit will contain one of the two shown Diagnostic Harnesses.

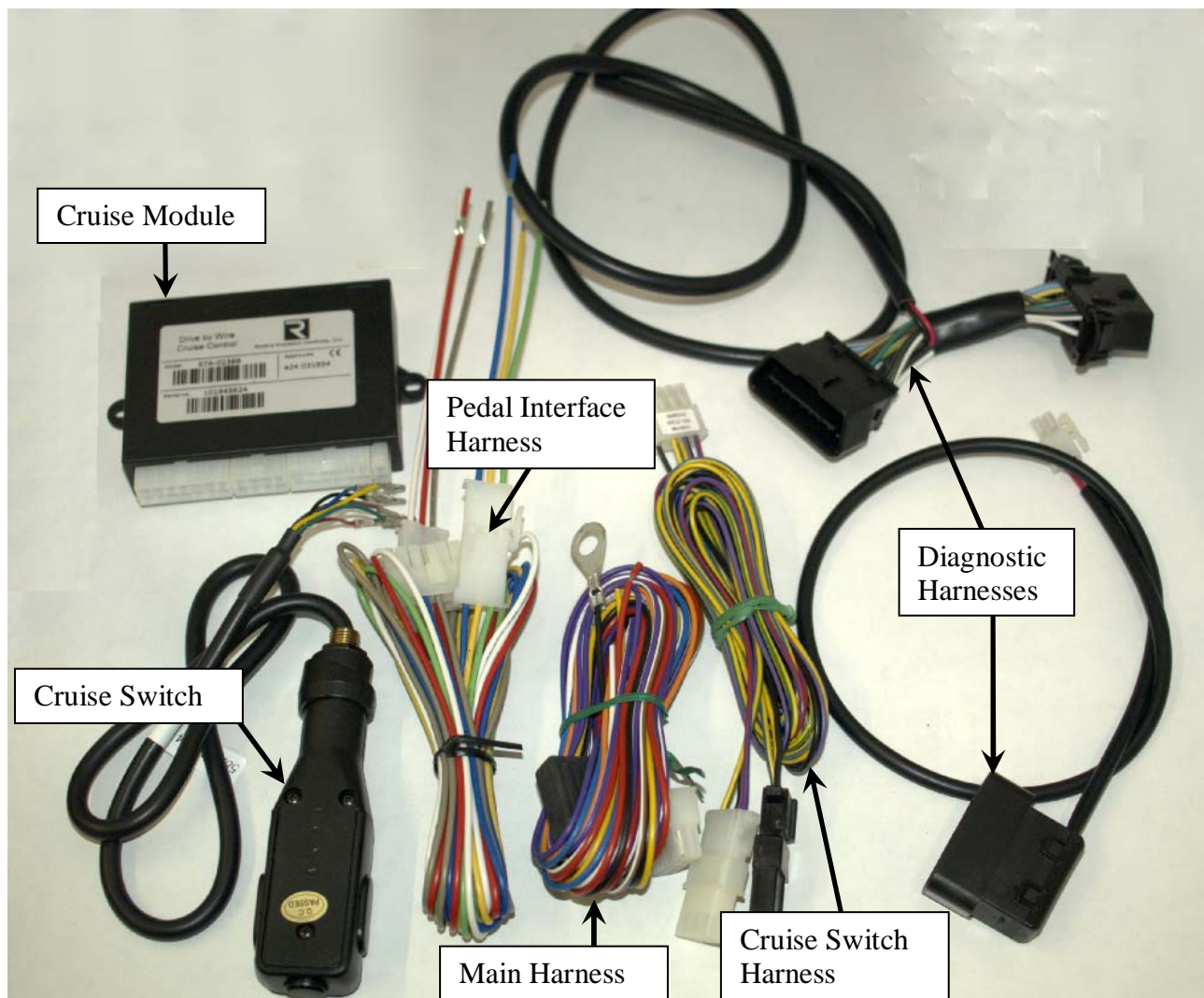

Installation procedure (All vehicles)

1. Turn vehicle key to "run" position. Do not start engine.
2. Locate BRAKE SWITCH WIRE HARNESS (BSWH). This harness is attached to the brake pedal.
3. Use Multimeter (DC Voltage measurement) on BSWH to find wire which is +12V all the time. This is the Brake+ (Brk+) wire. Write down Brk+ wire color here: _____
4. Use Multimeter (DC Voltage measurement) on BSWH to find wire which is: 0.0V Brake is unpressed AND +12V Brake is pressed. This is Brake- (Brk-) Write down Brk- wire color here: _____

For Manual Transmission vehicles ONLY

1. Locate CLUTCH SWITCH WIRE HARNESS (CSWH). This harness is attached to Clutch pedal
2. Use Multimeter (DC Voltage measurement) on CSWH to locate a wire which changes to +12V OR 0V when the clutch is pressed.
Write down Clutch switch wire color here: _____
3. If clutch switch wire goes to:
 - a. 12V when clutch is pressed, use YELLOW cruise clutch wire
 - b. 0V when clutch is pressed, use WHITE cruise clutch wire.
4. Write down Cruise Clutch wire color here: _____

5. Locate ignition wire -- this wire must be +12V when key is on and 0V otherwise
Write down IGN wire location here: _____
6. Locate Ground (GND) point -- this point must have 3 ohm or less resistance to Battery- terminal.
Typical location is behind the driver-side kick panel:
Write down GND point location here: _____
7. Turn key off and disconnect negative battery terminal.
8. Locate VEHICLE ACCELERATOR PEDAL HARNESS. Cut the prescribed wires at least 2" away from the pedal connector and strip 1/2" of insulation from the wire ends. Solder cruise PEDAL INTERFACE HARNESS to VEHICLE ACCELERATOR HARNESS as directed according to application. Wrap exposed conductor with electrical tape.
9. For the IGN, Brk+, Brk-, Cruise Clutch wires in the vehicle: remove 1/2" insulation from wire -DO NOT CUT WIRE- and solder appropriate cruise control MAIN HARNESS wire. Wrap exposed conductor with electrical tape.
10. Connect the CONTROL SWITCH HARNESS according the diagram at the end of the manual. (Do not drill the steering column shroud yet)
11. Locate the vehicle OBD II DIAGNOSTIC CONNECTOR. Connect the male end of the DIAGNOSTICS HARNESS to the vehicle OBD II DIAGNOSTIC CONNECTOR. Plug the 2-pin end in to the CRUISE MODULE according to the diagram.
12. Connect the MAIN WIRE and PEDAL INTERFACE HARNESSES to the CRUISE MODULE and reconnect negative battery terminal.
13. Test drive the vehicle. Ensure the cruise will engage above 30mph. Ensure that cruise will cancel on brake press, clutch press (manual trans. only), and "N" position of the gear selector (Manual transmissions, use clutch to make the shift, do not perform any operation that can damage the transmission).
14. If cruise performs as described in step 13, proceed to step 15. If cruise does not behave per as described in step 13, go back to beginning and verify work. If this is your second time through, consult the troubleshooting guides at <http://www.rostra.com/technical.htm>
15. Unplug the CONTROL SWITCH WIRE HARNESS from the cruise control.
16. Install the CONTROL SWITCH in to the LOWER STEERING COLUMN SHROUD – the switch is designed to be installed on the left side of the shroud. Run the harness through the steering column to the cruise module and reconnect the CONTROL SWITCH WIRE HARNESS in to the cruise control.
17. Remove the vehicle OBD II DIAGNOSTIC CONNECTOR from the interior panel. Connect the male end of the DIAGNOSTICS HARNESS to the vehicle OBD II DIAGNOSTIC CONNECTOR and insert the female end of the DIAGNOSTICS HARNESS to the interior panel diagnostic connector cutout. Note: Rostra Precision Controls has chosen the OBD II connector which fits the widest possible number of applications however; the interior panel may have to be modified slightly.
18. Mount the cruise control inside the dash in a secure location near the driver's side wall.
19. Secure all wiring harnesses using zip-ties.

The installation is now complete. Thank you for choosing Rostra Precision Controls!

E/F SERIES VEHICLES 250-9500/250-9501

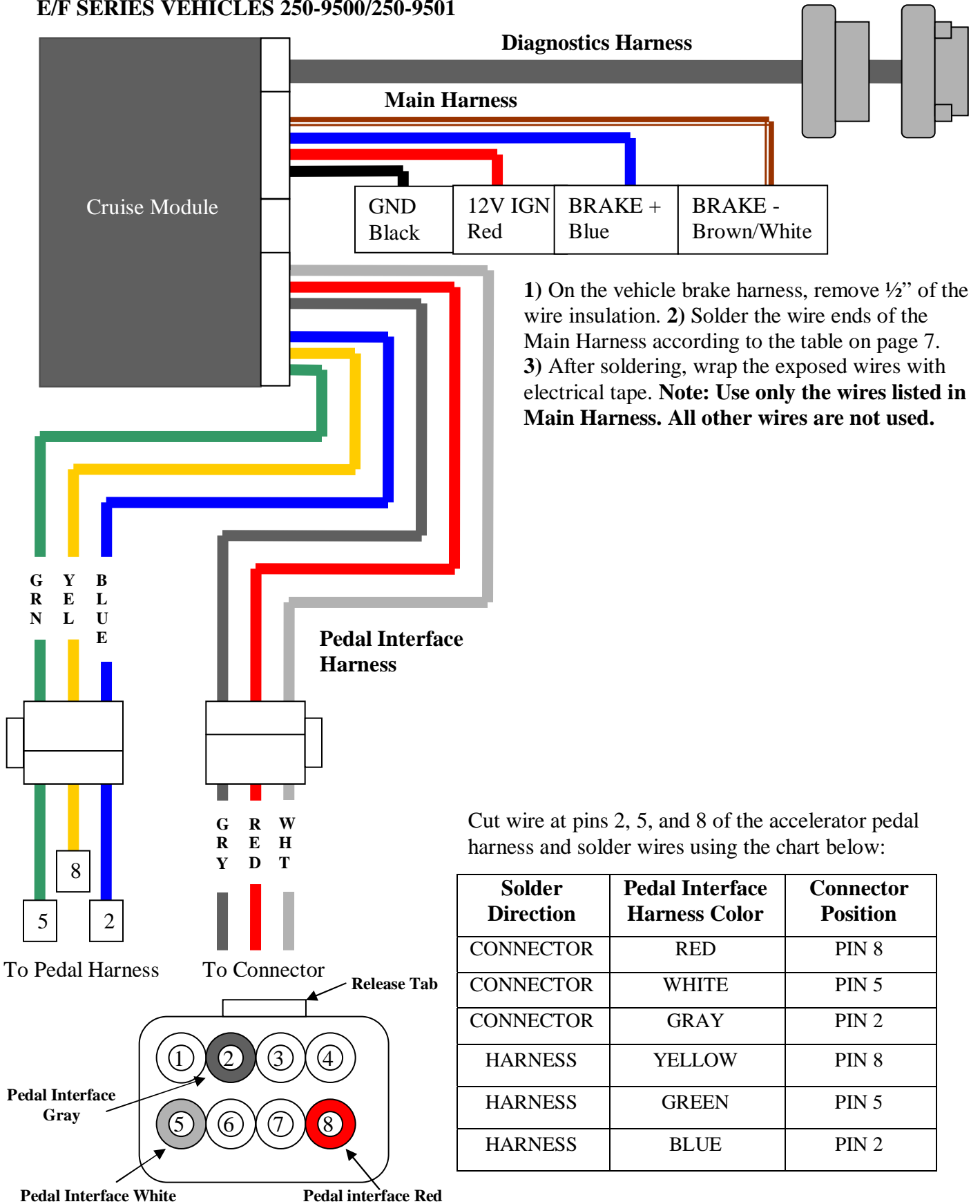

MAZDA 3 250-9502

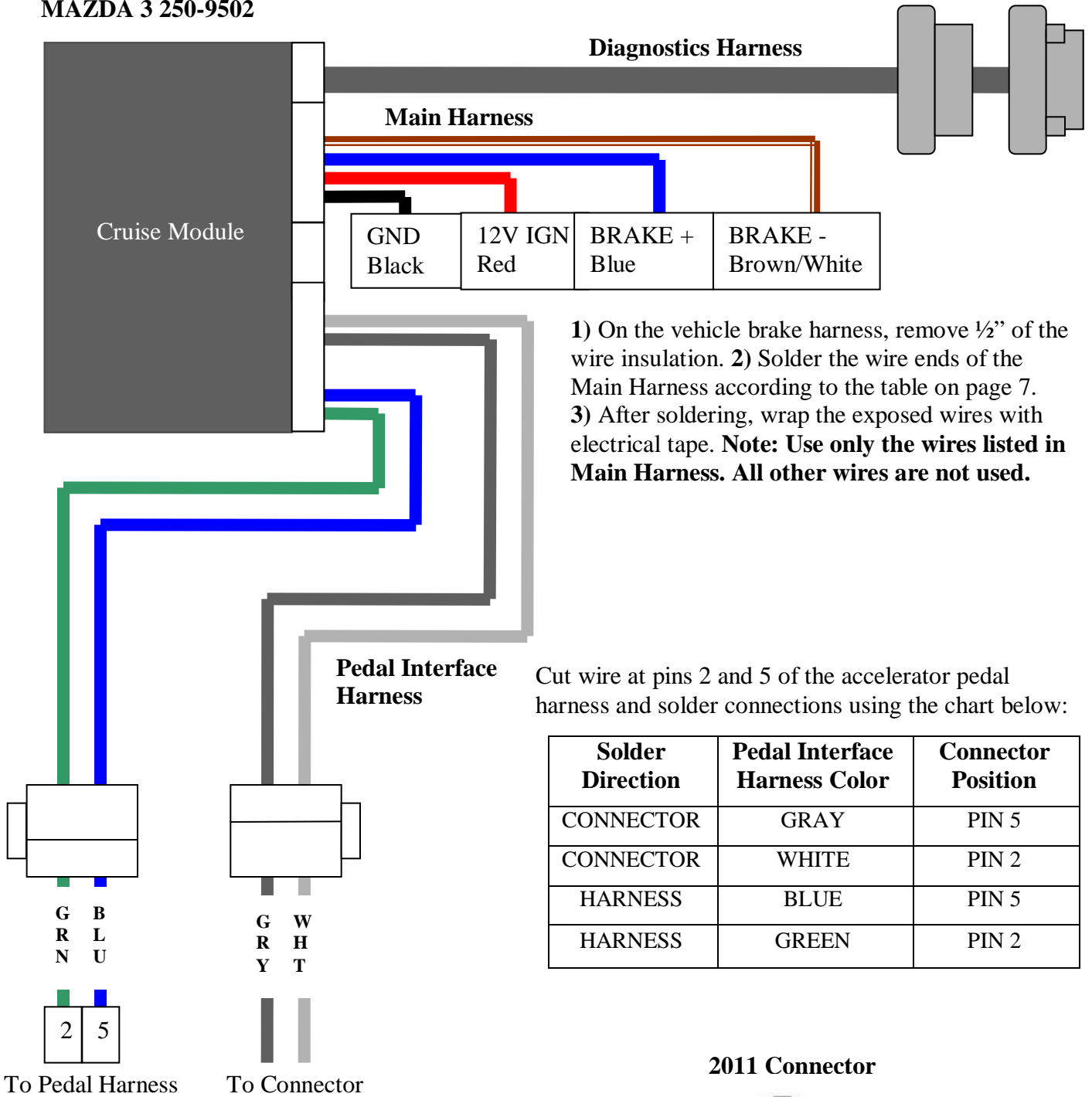

- 1) On the vehicle brake harness, remove 1/2" of the wire insulation.
- 2) Solder the wire ends of the Main Harness according to the table on page 7.
- 3) After soldering, wrap the exposed wires with electrical tape. **Note: Use only the wires listed in Main Harness. All other wires are not used.**

Cut wire at pins 2 and 5 of the accelerator pedal harness and solder connections using the chart below:

Solder Direction	Pedal Interface Harness Color	Connector Position
CONNECTOR	GRAY	PIN 5
CONNECTOR	WHITE	PIN 2
HARNESS	BLUE	PIN 5
HARNESS	GREEN	PIN 2

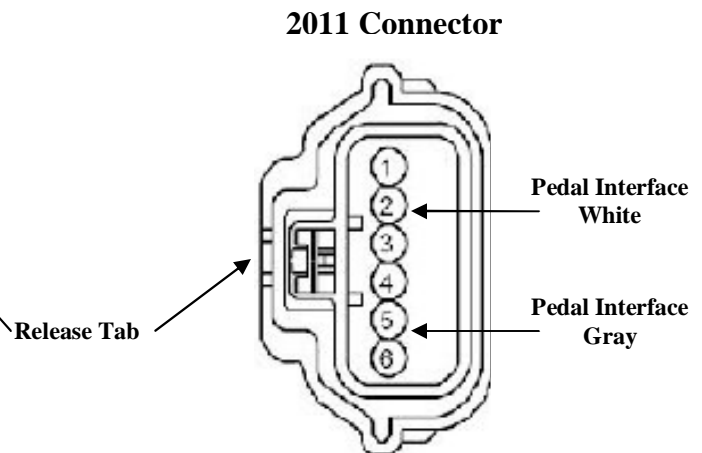
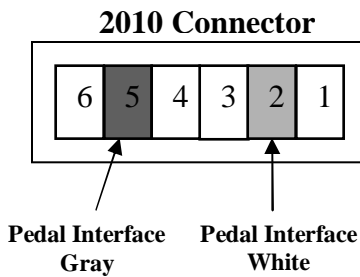

MAZDA 6 250-9503

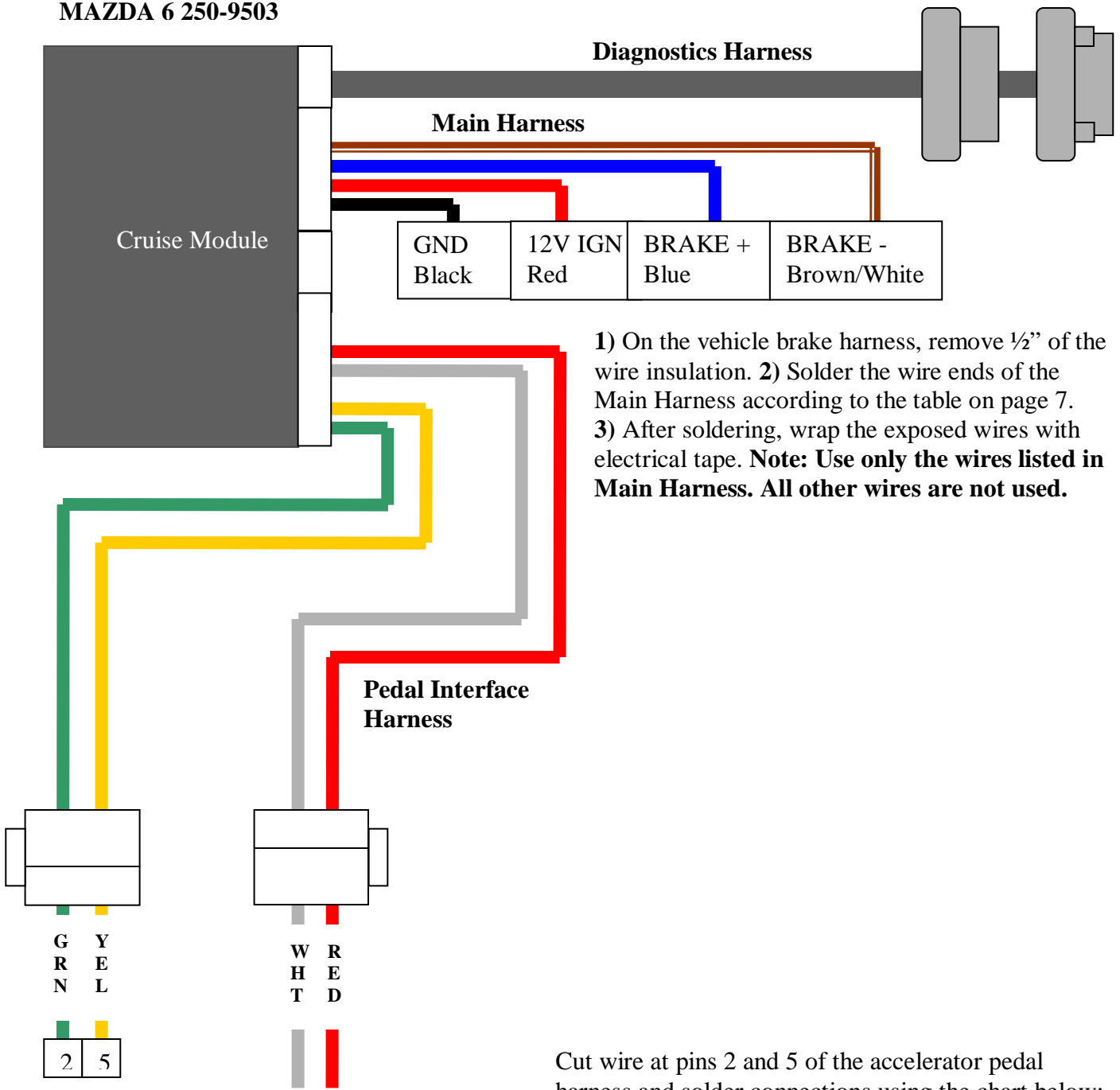

- 1) On the vehicle brake harness, remove 1/2" of the wire insulation.
- 2) Solder the wire ends of the Main Harness according to the table on page 7.
- 3) After soldering, wrap the exposed wires with electrical tape. **Note: Use only the wires listed in Main Harness. All other wires are not used.**

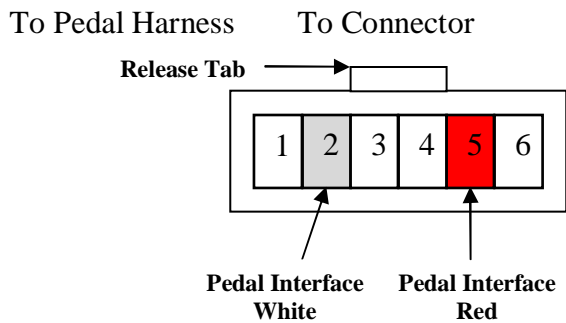

Cut wire at pins 2 and 5 of the accelerator pedal harness and solder connections using the chart below:

Solder Direction	Pedal Interface Harness Color	Connector Position
CONNECTOR	RED	PIN 5
CONNECTOR	WHITE	PIN 2
HARNESS	YELLOW	PIN 5
HARNESS	GREEN	PIN 2

NISSAN VERSA 250-9504

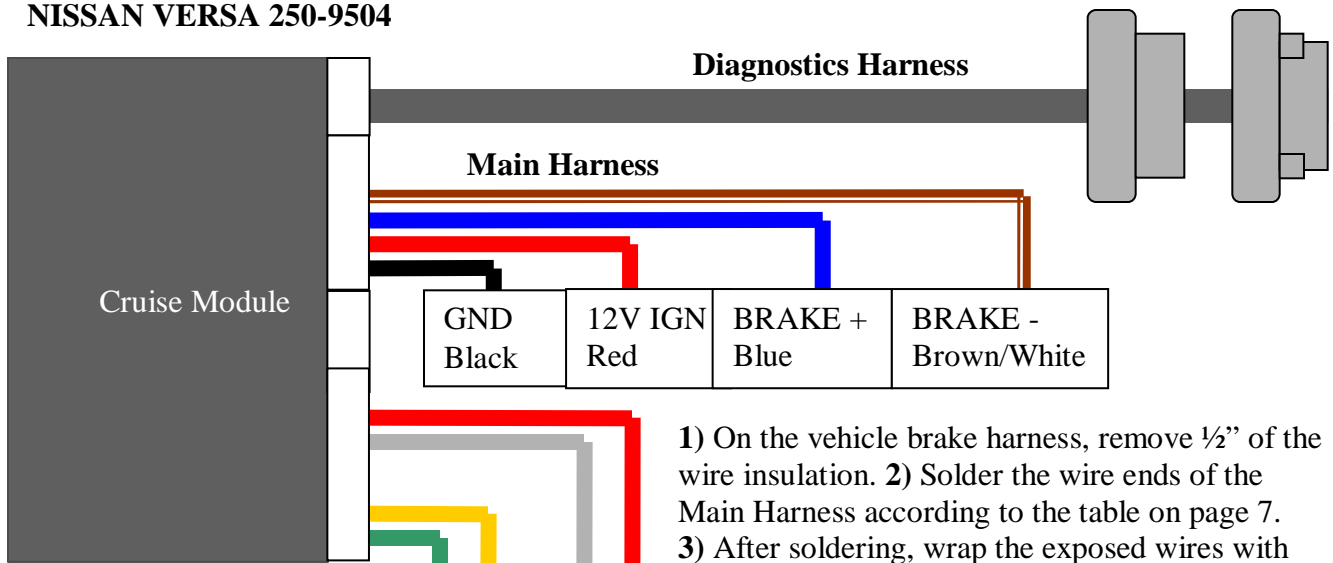

GND Black	12V IGN Red	BRAKE + Blue	BRAKE - Brown/White
--------------	----------------	-----------------	------------------------

- 1) On the vehicle brake harness, remove 1/2" of the wire insulation.
- 2) Solder the wire ends of the Main Harness according to the table on page 7.
- 3) After soldering, wrap the exposed wires with electrical tape. **Note: Use only the wires listed in Main Harness. All other wires are not used.**

On the vehicle accelerator, remove the accelerator pedal connector and insert the plug-and-play harness in to the appropriate mating connectors. See picture below.

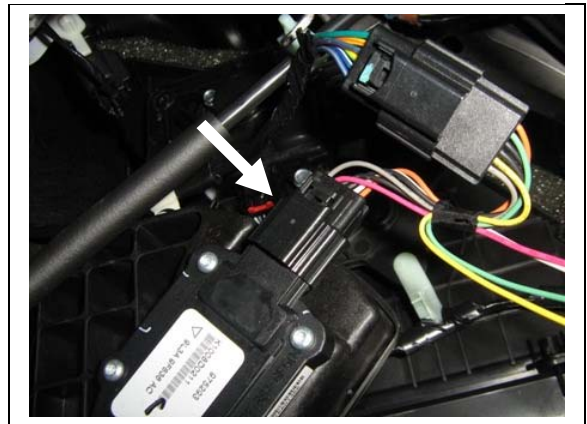
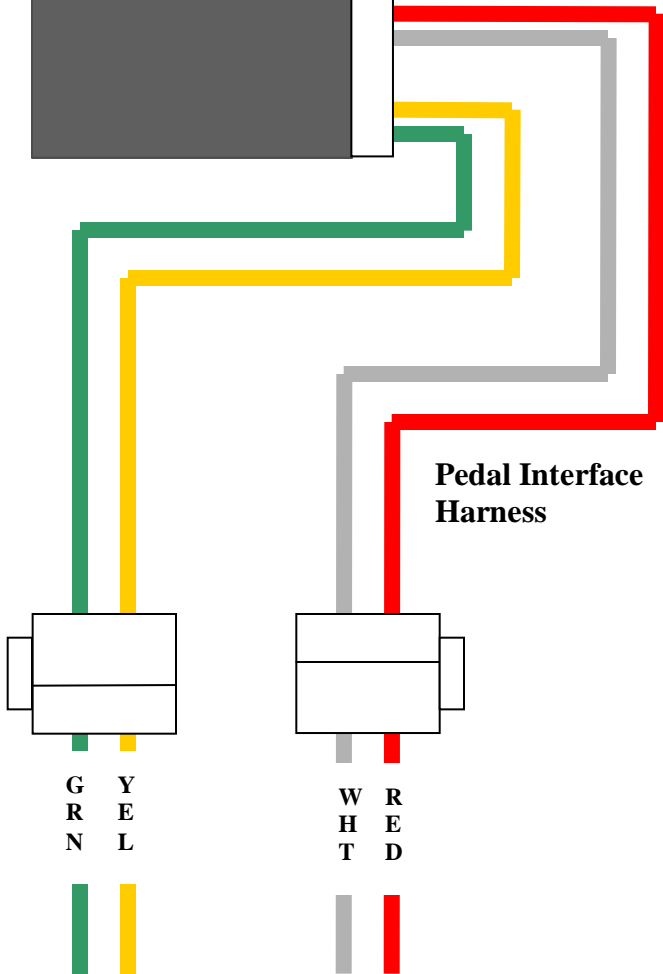

ALL VEHICLES

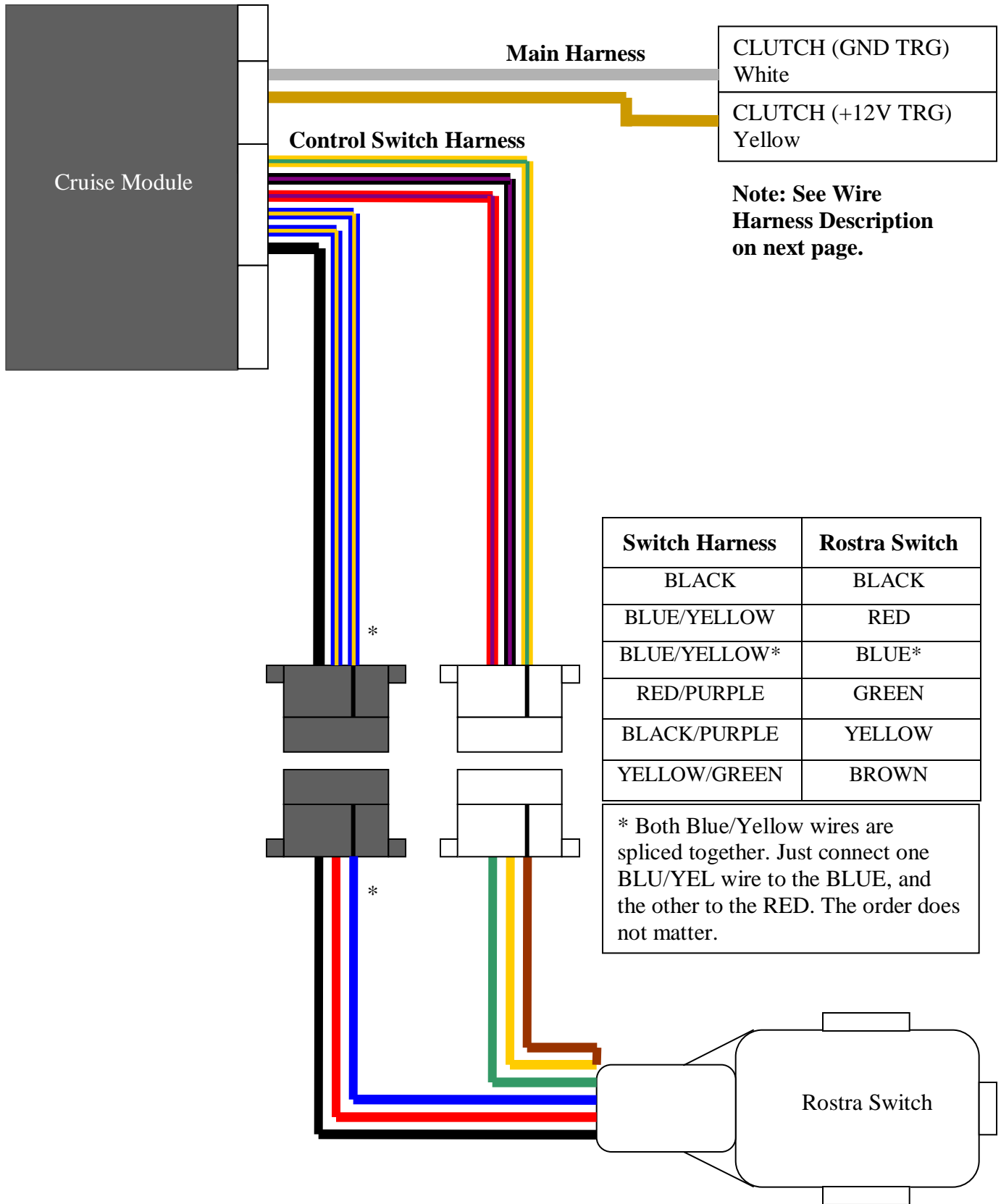

ALL VEHICLES

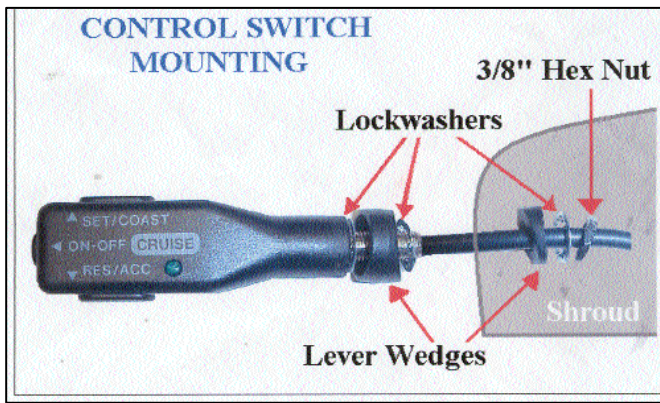

Use the lever wedges on the Control Switch at an angle template to drill a 3/8" or 9.5mm hole

Switch Testing

Function	Color	Results
SET	GREEN	12V Press and hold
RESUME	YELLOW	12V Press and hold
ON/OFF	BROWN	12V Press ON
12V POWER	RED	12V
12V POWER	BLUE	12V
GROUND	BLACK	(0) ohms to ground

MAIN WIRING HARNESS DESCRIPTION

Function	Color	Results	Fault Conditions
Ignition	Red	+12V when switched on and +0V when switched off. Ignition must be greater than +10V while cranking vehicle.	No power, voltage drop, or intermittent connection will cause Loss of pedal or "Limp Mode" condition.
Brake positive +	Blue	"Hot" side of brake switch. +12V all the time.	Cruise will not function if this connection is not installed correctly.
Brake negative -	Brown/White	"Cold" side of Brake switch. Zero (0) resistance to ground when brake is not pressed. +12V when brake is pressed.	Cruise will not function if this connection is not installed correctly. If connection is good, and there is a high resistance to ground, a 5 terminal relay will be required to complete installation. See diagram below.
Ground	Black	Lowest resistance to ground closest to zero (0) ohms as possible. Use a vehicle ground point where other ground wires are connected to.	A bad ground connection will cause the following conditions: Cruise will not function; Loss of pedal or "Limp Mode" condition.
Clutch (GND triggered)	White	Ground active wire at switch when clutch is depressed.	Cruise will not function if wrong wire is connected –OR– ⚠ Cruise will not disengage when clutch is depressed.
Clutch (+12V triggered)	Yellow	+12V active wire at switch when clutch is depressed.	Cruise will not function if wrong wire is connected –OR– ⚠ Cruise will not disengage when clutch is depressed.

5 Terminal Relay for Brake Switch

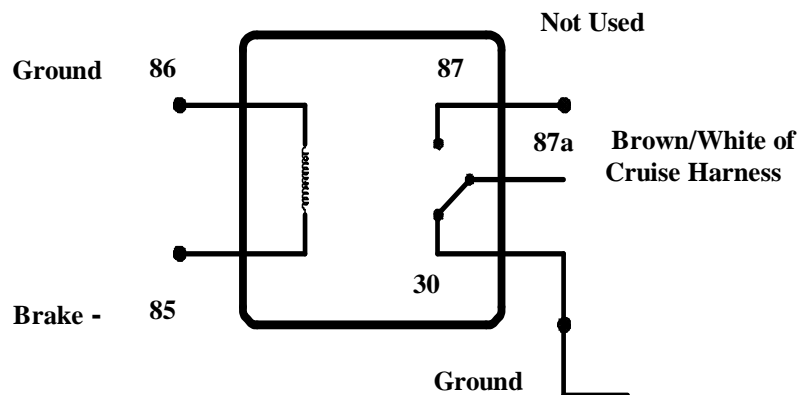

TROUBLE SHOOTING

If a "Check Engine" code or Wrench light appears, disconnect negative side of battery. Plug the 2-pin or 3-pin mating connectors into each other as shown. Reconnect negative side of battery. Start engine and depress accelerator to confirm operation. If "Check Engine" code or Wrench light appears again, ensure proper wire matching and good solder connections. Be sure to turn off engine and disconnect battery before reinstalling. Refer to <http://www.rostra.com/technical.htm> for additional troubleshooting documents.

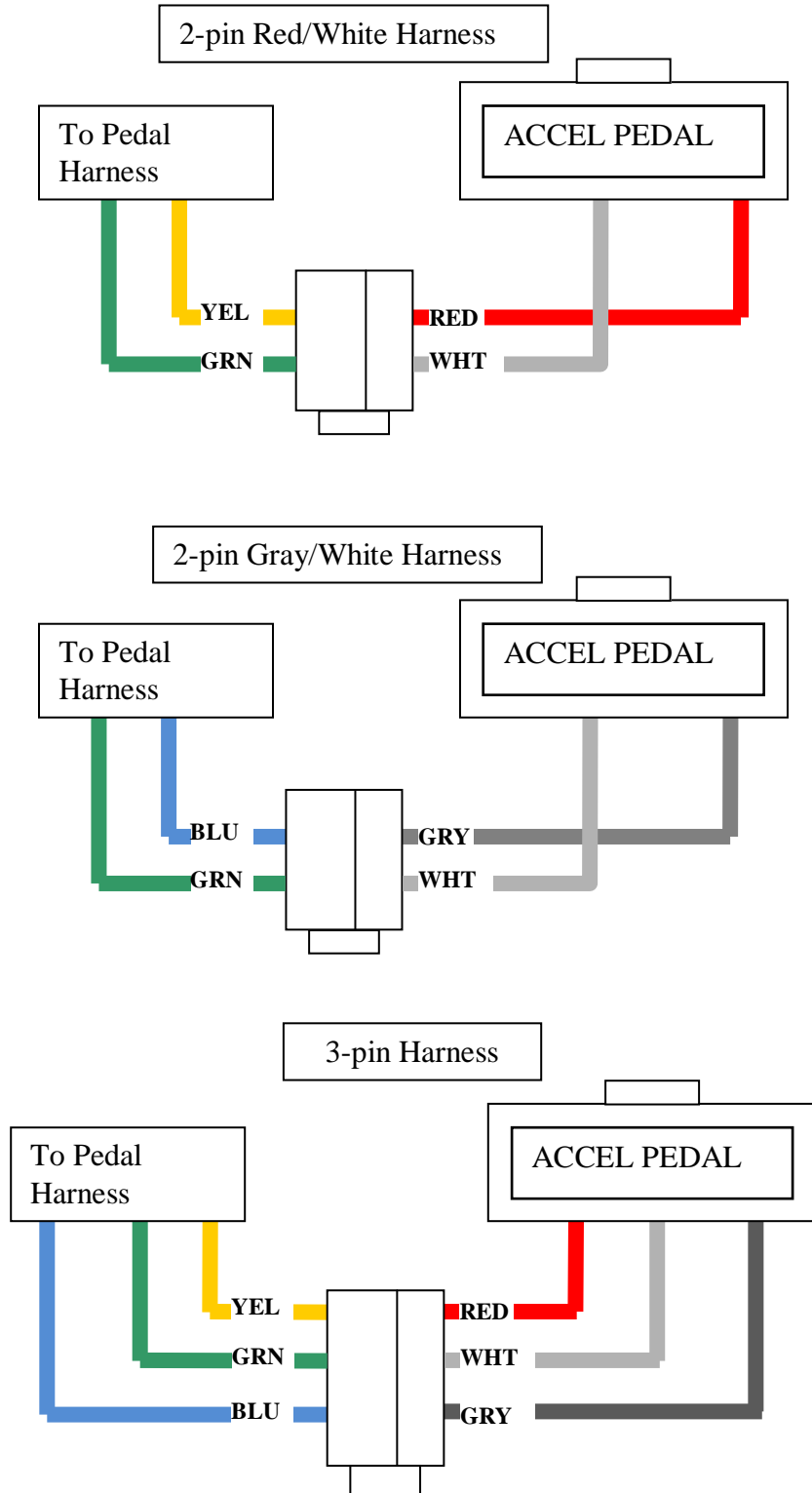

NOTES

