

HONDA / HYUNDAI / KIA

Part Number: 250-1859

ELECTRONIC CRUISE KIT

AUTOMATIC AND MANUAL TRANSMISSION

General Applicability

2010 Honda Insight
 07- Kia Optima / Forte / Rondo/ 10- Sedona /
 12 Kia Soul / Rio
 10- Hyundai Tucson / Elantra Touring ETC
 2012 Accent / Elantra/ Genesis

Item #	Qty.	Description
1. 250-2763	1	Cruise Control Module
2. 250-2760	1	Switch Harness
3. 250-2759	1	Main Wiring Harness
4. 250-2771	1	Pedal Interface Harness
5. 250-2767	1	Hardware Kit
6. 250-3742	1	Control Switch

Kit Contents/Service Parts

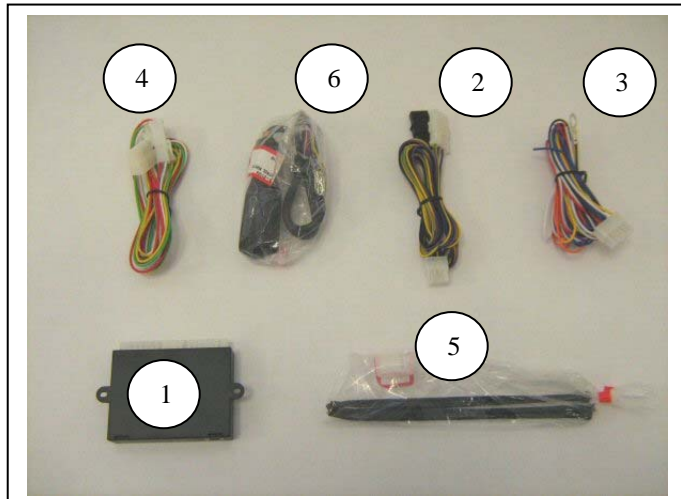

Contents of Hardware Bag

Qty	Description
8	Wire Zip Ties

Recommended Tools

Safety Tools	
Gloves, Safety Glasses	
Special Tools	
Volt-Ohm Meter	
Installation Tools	
Side cutter	To cut wire ties
Drill Bit or Knockout Punch	9.5mm or 3/8" (for switch)
10mm wrench	
Soldering Tool	
Special Chemicals	

Conflicts

Note:

Recommended Sequence of Application

Item #	Accessory
1	
2	
3	

Legend

	STOP: Damage to the vehicle may occur. Do not proceed until process has been complied with.
	OPERATOR SAFETY: Use caution to avoid risk of injury
	CRITICAL PROCESS: Proceed with caution to ensure a quality installation.
	GENERAL PROCESS: This highlights specific processes to ensure a quality installation.
	TOOLS & EQUIPMENT: This calls out the specific tools and equipment required for this process

DUE TO SENSITIVE NATURE OF SIGNALS USED FOR THIS PRODUCT ALL NON PLUG AND PLAY CONNECTIONS MUST BE SOLDERED.





FAILURE TO COMPLY WITH THIS REQUIREMENT WILL VOID WARRANTY.

THIS DEVICE IS NOT INTENDED FOR USE IN VEHICLES WITH 2-WAY RADIOS.



Section I – Installation Procedure

A. Pre-Installation Suggestions

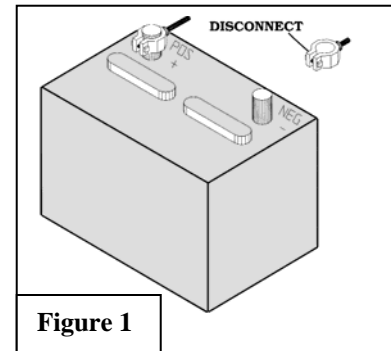
- 1.  It is advisable to disconnect the negative battery cable for 3 minutes before beginning installation, to avoid unintended air bag deployment. Note and record any anti-theft radio codes prior to disconnecting. **Figure 1**
- 2.  Remove the driver side lower dash and kick panels. Remove the steering wheel shroud.



B. Install Electronic Module

- 1.   Plug in the **Main Wiring Harness, Switch Harness, and Pedal Interface Harness** onto mating connectors of the **Cruise Control Module**. **Figure 2**
- 2. Place the **Cruise Control Module** in a secure location behind the driver side dash area near the firewall away from moving parts. Secure with supplied wire ties.
- 3. Route the **Pedal Interface Harness** through steering column and down to the accelerator.

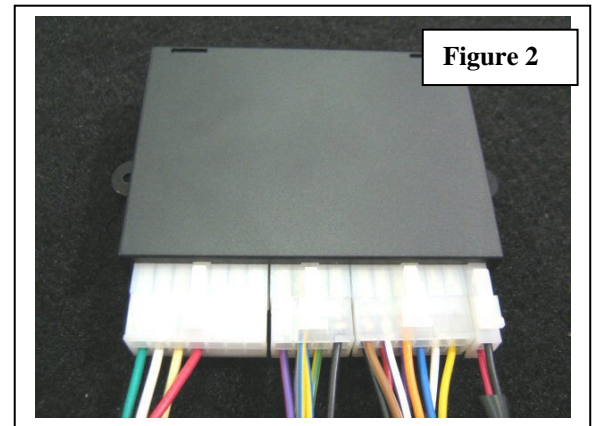

C. Install Pedal Interface Harness

1. Use the diagram and chart below to install the pedal interface harness. Disconnect the Pedal Interface Harness at the 2-pin connectors to ease installation of solder connections. Cut the selected wires at the accelerator harness leaving at least 2 inches of harness from the connector. Solder the wire ends from the pedal interface harness to the accelerator pedal harness according to each wire color listed in chart. **After soldering, wrap the exposed wires with electrical tape. Figure 3.**



WARNING: PROCEED WITH CAUTION TO BE SURE PEDAL INTERFACE HARNESS IS MATED PROPERLY TO THE ACCELERATOR HARNESS. FAILURE TO DO THIS CORRECTLY WILL DISABLE THE ACCELERATOR.

: Solder Joint

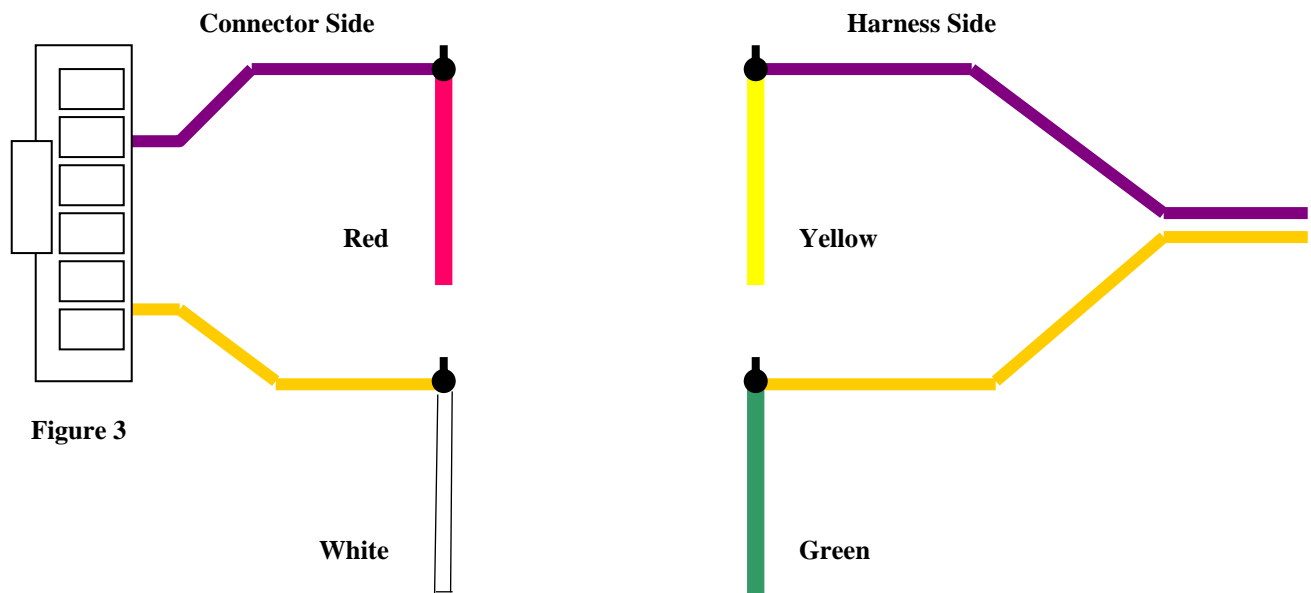

Figure 3

INSIGHT CONNECTIONS

Splice & Solder Direction	Cruise Harness Color	Vehicle Wire
CONNECTOR	RED	VIOLET
CONNECTOR	WHITE	YELLOW
HARNESS	YELLOW	VIOLET
HARNESS	GREEN	YELLOW

TUCSON CONNECTIONS

Splice & Solder Direction	Cruise Harness Color	Vehicle Wire
CONNECTOR	RED	BLUE/ORANGE
CONNECTOR	WHITE	ORANGE
HARNESS	YELLOW	BLUE/ORANGE
HARNESS	GREEN	ORANGE

Pedal Interface Harness Connections Continued....



07-10 OPTIMA, RONDO CONNECTIONS

Splice & Solder Direction	Cruise Harness Color	Vehicle Wire
CONNECTOR	RED	BLUE
CONNECTOR	WHITE	GREEN/ORANGE
HARNESS	YELLOW	BLUE
HARNESS	GREEN	GREEN/ORANGE

FORTE CONNECTIONS

Splice & Solder Direction	Cruise Harness Color	Vehicle Wire
CONNECTOR	RED	GRAY
CONNECTOR	WHITE	ORANGE
HARNESS	YELLOW	GRAY
HARNESS	GREEN	ORANGE

10- SEDONA CONNECTIONS

Splice & Solder Direction	Cruise Harness Color	Vehicle Wire
CONNECTOR	RED	GREEN/ORANGE
CONNECTOR	WHITE	WHITE
HARNESS	YELLOW	GREEN/ORANGE
HARNESS	GREEN	WHITE
VSS DIAGNOSTICS WHITE/BLACK WIRE		

11 OPTIMA CONNECTIONS

Splice & Solder Direction	Cruise Harness Color	Vehicle Wire
CONNECTOR	RED	GREEN/BLACK
CONNECTOR	WHITE	YELLOW/ORANGE
HARNESS	YELLOW	GREEN/BLACK
HARNESS	GREEN	YELLOW/ORANGE
VSS DIAGNOSTICS WHITE WIRE		

2012 GENESIS CONNECTIONS

Splice & Solder Direction	Cruise Harness Color	Vehicle Wire
CONNECTOR	RED	YELLOW
CONNECTOR	WHITE	PINK
HARNESS	YELLOW	YELLOW
HARNESS	GREEN	PINK
VSS DIAGNOSTICS BLUE WIRE PIN 3		

2012 ELANTRA CONNECTIONS

Splice & Solder Direction	Cruise Harness Color	Vehicle Wire
CONNECTOR	RED	BLUE
CONNECTOR	WHITE	PINK
HARNESS	YELLOW	BLUE
HARNESS	GREEN	PINK
VSS DIAGNOSTICS YELLOW WIRE PIN 3		

2012 ACCENT CONNECTIONS

Splice & Solder Direction	Cruise Harness Color	Vehicle Wire
CONNECTOR	RED	YELLOW
CONNECTOR	WHITE	GREEN
HARNESS	YELLOW	YELLOW
HARNESS	GREEN	GREEN
VSS DIAGNOSTICS PINK WIRE PIN 3		

2012 SOUL CONNECTIONS

Splice & Solder Direction	Cruise Harness Color	Vehicle Wire
CONNECTOR	RED	PIN 1
CONNECTOR	WHITE	PIN 3
HARNESS	YELLOW	PIN 1
HARNESS	GREEN	PIN 3
VSS DIAGNOSTICS RED/ORANGE WIRE PIN 3		

Pedal Interface Harness Connections Continued....

2012 RIO CONNECTIONS

Splice & Solder Direction	Cruise Harness Color	Vehicle Wire
CONNECTOR	RED	YELLOW
CONNECTOR	WHITE	WHITE
HARNESS	YELLOW	YELLOW
HARNESS	GREEN	WHITE
VSS DIAGNOSTICS BROWN WIRE PIN 3		

2. Check for good solder connection:
Before continuing cruise installation, plug the 2-pin mating connectors in to each other as shown in **Figure 4**. Reconnect negative side of battery. Start engine and depress accelerator to confirm operation. Turn off engine and disconnect battery.



- a. If a DTC code appears, restart Section C and ensure proper wire matching and good solder connections.
3. Unplug the 2-pin mating connectors from each other (connected together in the last step) and reconnect to the 2-pin mating connectors of Pedal Interface Harness. **Use electrical tape to wrap all connections.**

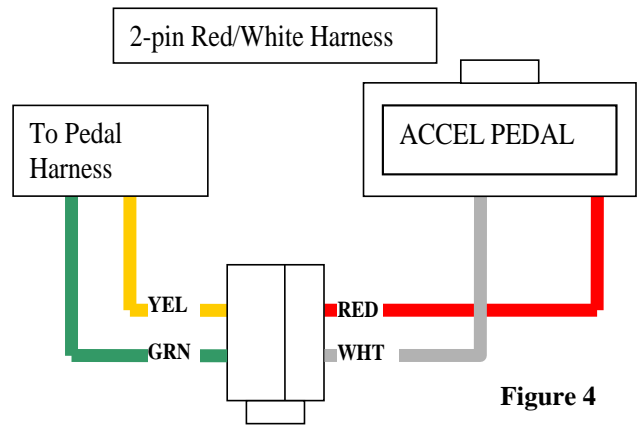

Figure 4

D. Wiring Connections (See Wiring Harness Description on last page)



1. The wiring locations are not listed for some vehicles in these instructions. Use the following wiring diagram with wiring harness description on last page to make the following connections:

Note: Only one of the two clutch wires is needed for the cruise installation on a vehicle with a manual transmission

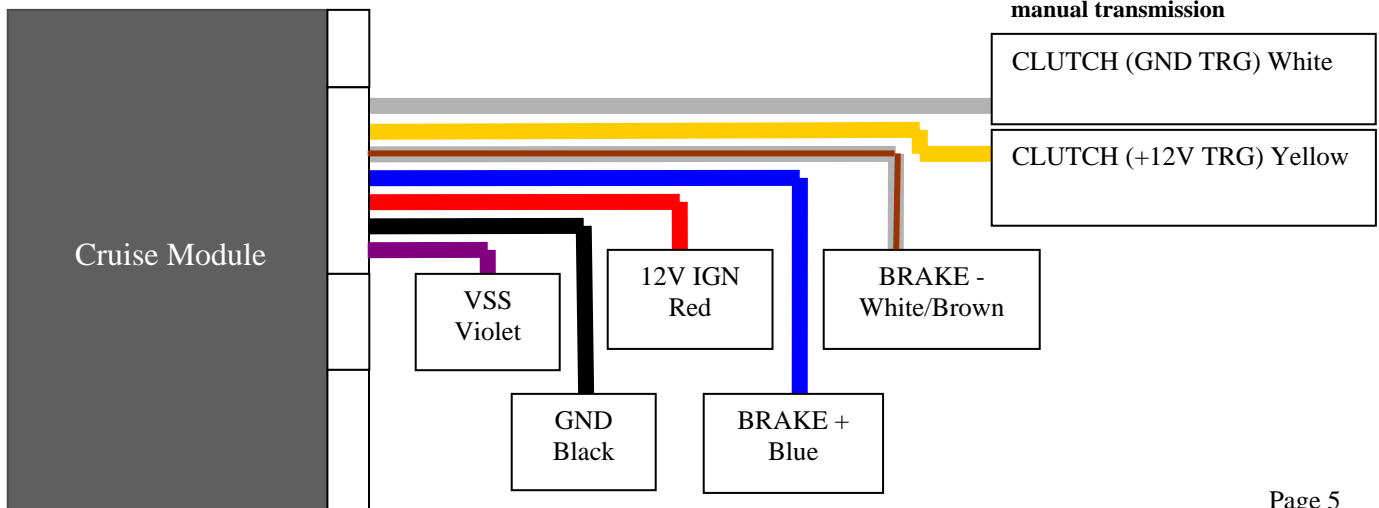

E. Insight Wiring Connections (It is advisable use solder for all wiring connections)



1. Locate the following wires to connect to the main harness from the control module:

Function	See Fig.	Vehicle Color
IGN	5	RED
BRAKE +	6	VIOLET
BRAKE -	6	WHITE
GROUND	7	GROUND POINT
VSS	8	BLUE
CLUTCH SWITCH		PAGE 4

2. Connect the Main Harness to vehicle wire by using the chart below.

Function	Cruise Harness Color	Vehicle Wire
IGN	RED	RED
BRAKE +	BLUE	VIOLET
BRAKE -	WHITE/BROWN	WHITE
VSS	VIOLET	BLUE
CLUTCH SWITCH	WHITE	PAGE 4

3. Apply the **Black Ground Wire** from the Main Harness to the Vehicle Ground Point at the kick panel. **Figure 7**
4. **VSS:** Locate the fuse/relay box under the driver side dash. Look for bottom **white connector** between yellow and blue connector. Connect the **Violet Wire** from the Main Wiring Harness to the **Blue Wire** of the connector. **Figure 8**

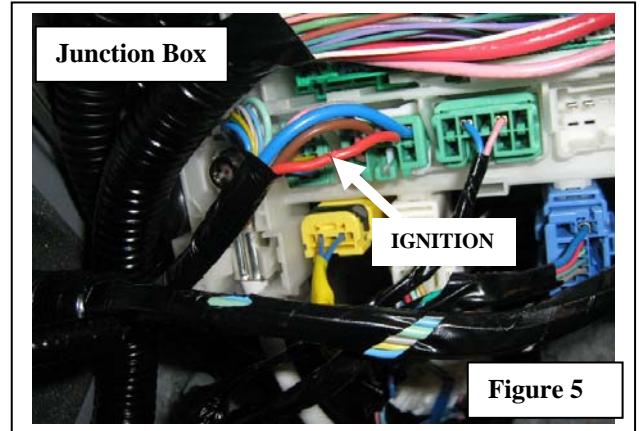

Figure 5

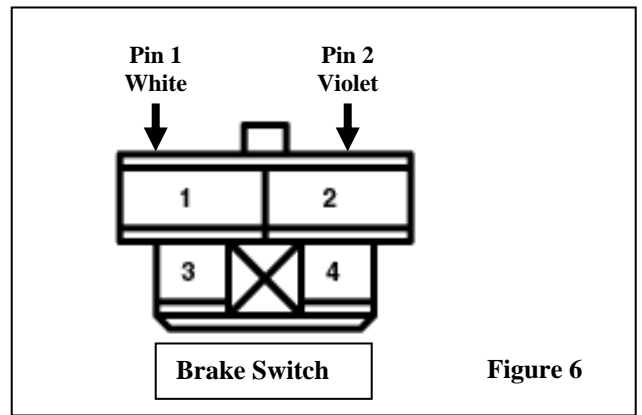

Figure 6

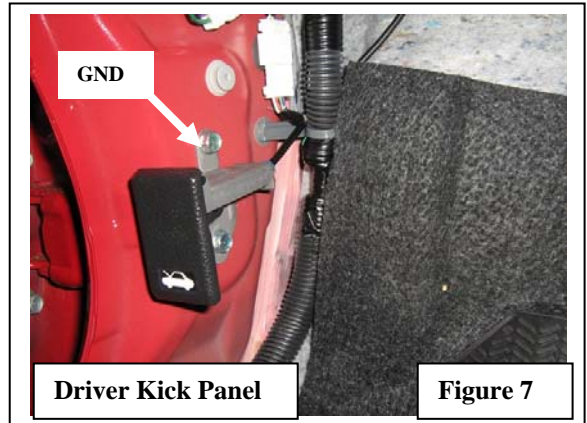

Figure 7

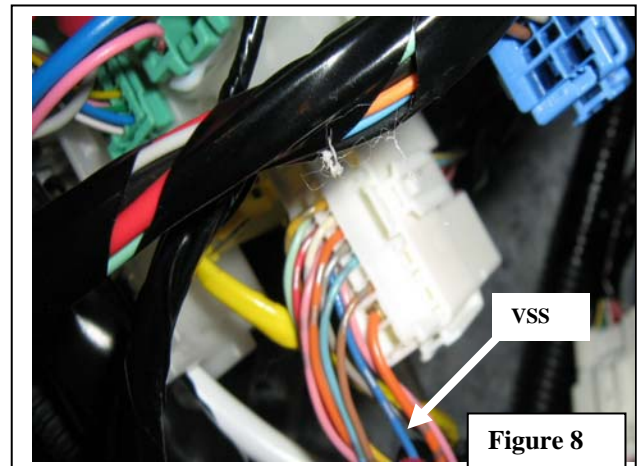

Figure 8

F. Tucson /Elantra Touring ETC Wiring Connections (It is advisable use solder for all wiring connections)



1. Locate the following wires to connect to the main harness from the control module:

Function	See Fig.	Vehicle Color
IGN	9	WHITE/BLACK OF BRAKE SWITCH
BRAKE +	9	WHITE/BLACK
BRAKE -	9	GREEN
GROUND	10	GROUND POINT
VSS	11	BROWN
CLUTCH SWITCH		PAGE 4

2. Connect the Main Harness to vehicle wire by using the chart below:

Function	Cruise Harness Color	Vehicle Wire
IGN	RED	WHITE/BLACK
BRAKE +	BLUE	WHITE/BLACK
BRAKE -	WHITE/BROWN	GREEN
VSS	VIOLET	BROWN
CLUTCH SWITCH	WHITE	PAGE 4

3. **VSS:** Locate the diagnostics connector under the driver side dash. Look for bottom **black connector** at bottom of dash panel. Connect the **Violet Wire** from the Main Wiring Harness to the **Brown Wire** in **Pin 6** of the connector. **Figure 11**

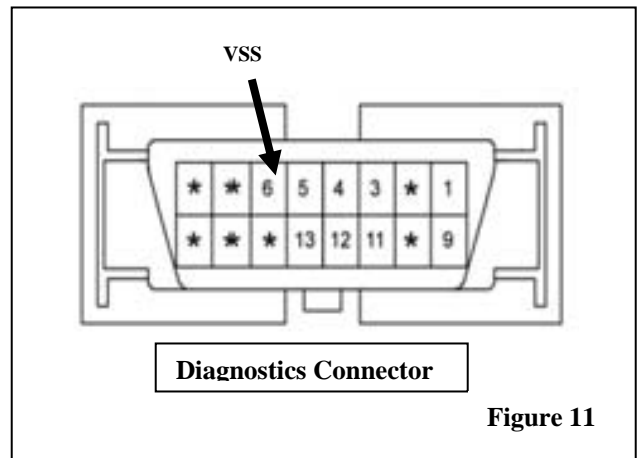
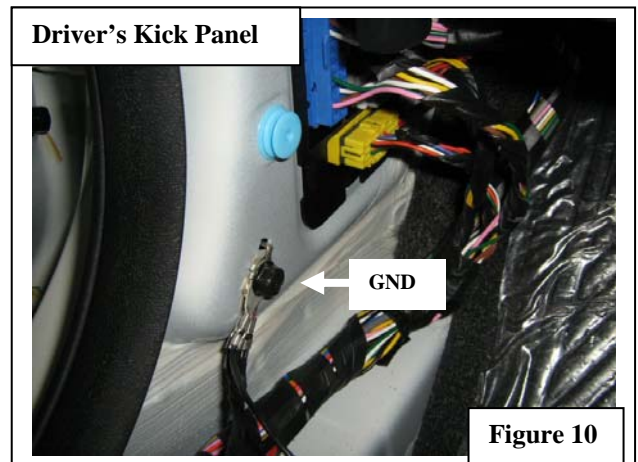
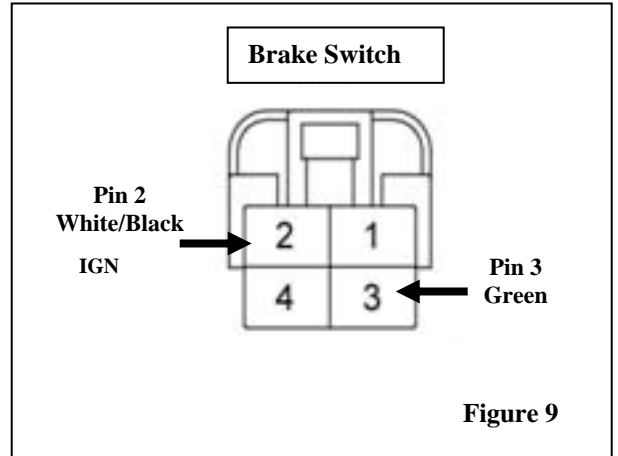

G. 07-10 Optima Wiring Connections (It is advisable use solder for all wiring connections)



1. Locate the following wires to connect to the main harness from the control module:

Function	See Fig.	Vehicle Color
IGN	12	RED
BRAKE +	13	PINK
BRAKE -	13	BROWN
GROUND	14	BLACK
VSS	15	GRAY
CLUTCH SWITCH	16	BLACK

2. Connect the Main Harness to vehicle wire by using the chart below:

Function	Cruise Harness Color	Vehicle Wire
IGN	RED	RED
BRAKE +	BLUE	PINK
BRAKE -	WHITE/BROWN	BROWN
VSS	VIOLET	GRAY OR BLUE
CLUTCH SWITCH	WHITE	BLACK

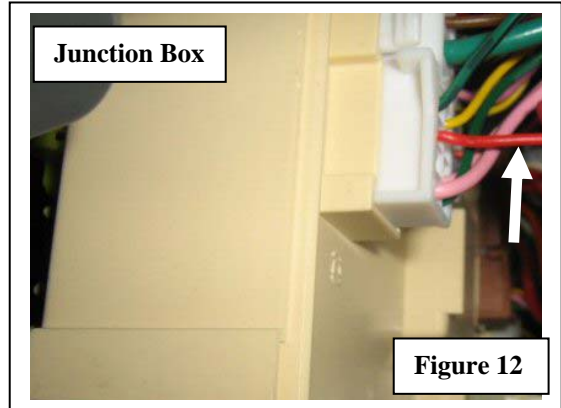

Figure 12

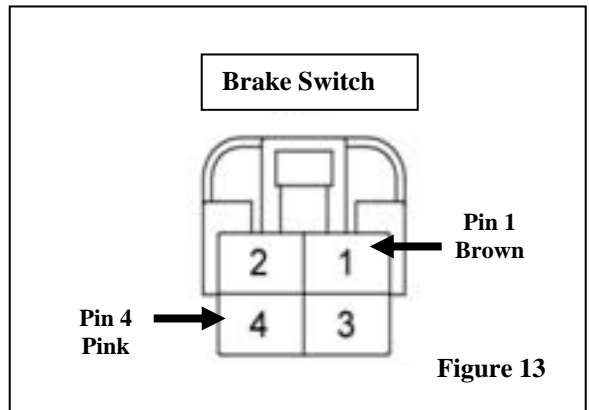

Figure 13

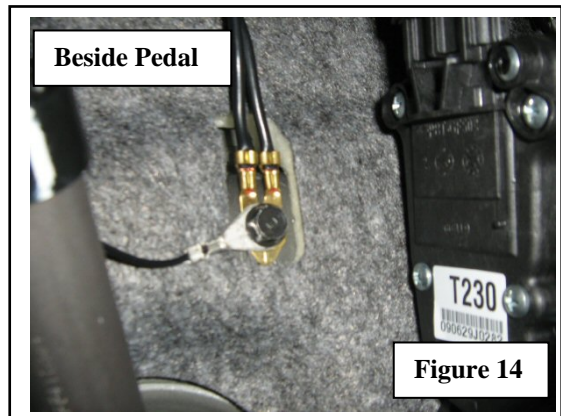
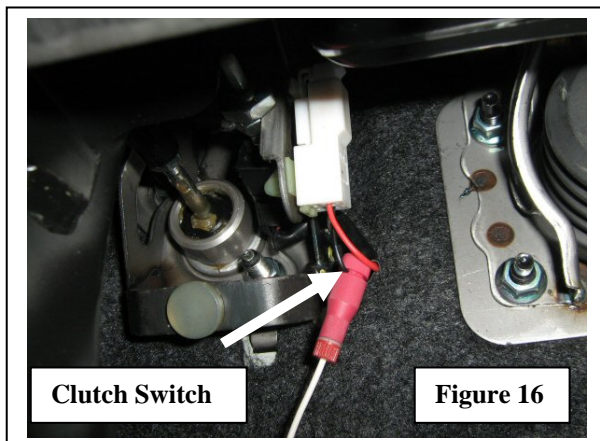
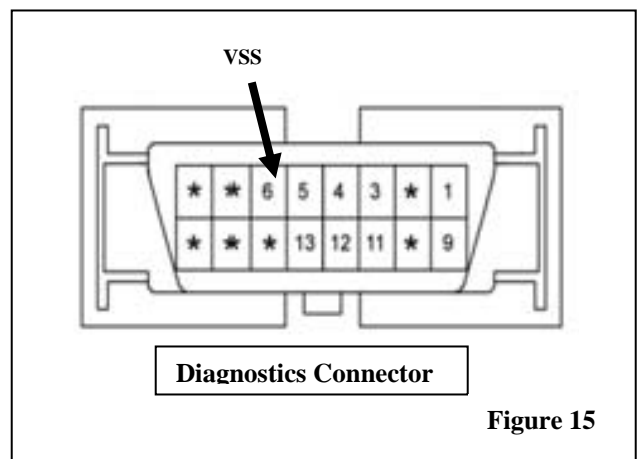

Figure 14



Clutch Switch

Figure 16



Diagnostics Connector

Figure 15

H. Install Control Switch



1. Use the **lever wedges** on the **Control Switch** at an angle template to drill a 3/8" or 9.5mm hole in the lower shroud of the steering column cover. Position lock-washers as shown. **Figure 19**
2. Apply nut and position **Control Switch** for driver's best view.
3. Assemble (2) 3-pin connectors from the sack parts to the mating wire colors on the **Control Switch Harness**. Use the diagram to mate the **module harness** to **switch harness**. **Figure 20**
4. Route the assembled **Control Switch Harness** to the mating connector of the **Cruise Control module**.
5. Secure the **Control Switch Harness** with zip ties away from moving parts.

I. Testing



1. Reconnect negative battery cable and torque to 35 in*lbs. Reenter anti-theft radio codes.
2. Turn ignition on. Apply the on/off button of Cruise Control Switch.

J. Reassembly



1. Reinstall all removed pieces taking care to ensure harnesses and wiring connections are properly secured.
2. Make sure all harnesses are not pinched or bound by trim pieces.

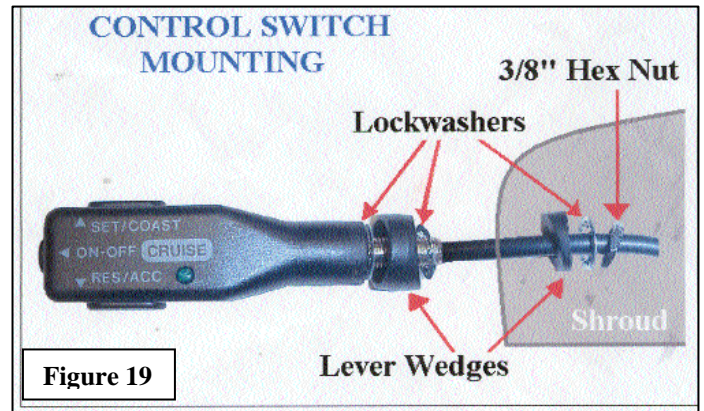

Figure 19

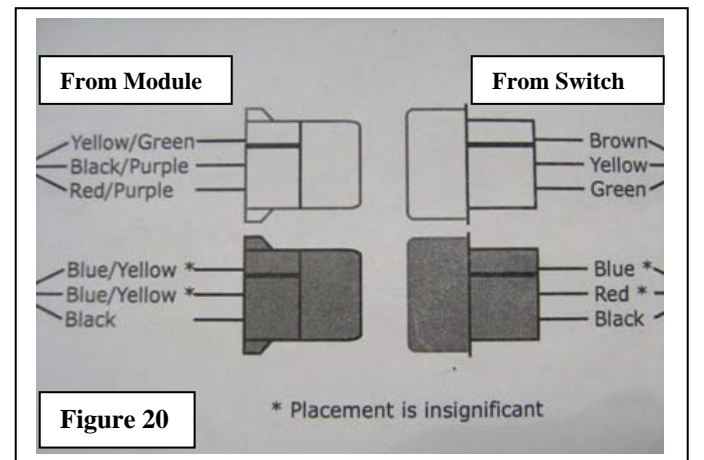
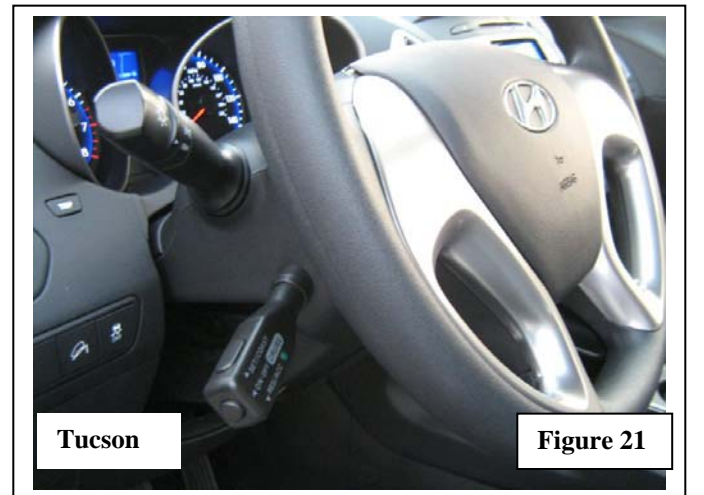

Figure 20



Tucson

Figure 21

Section II - Wiring Diagram

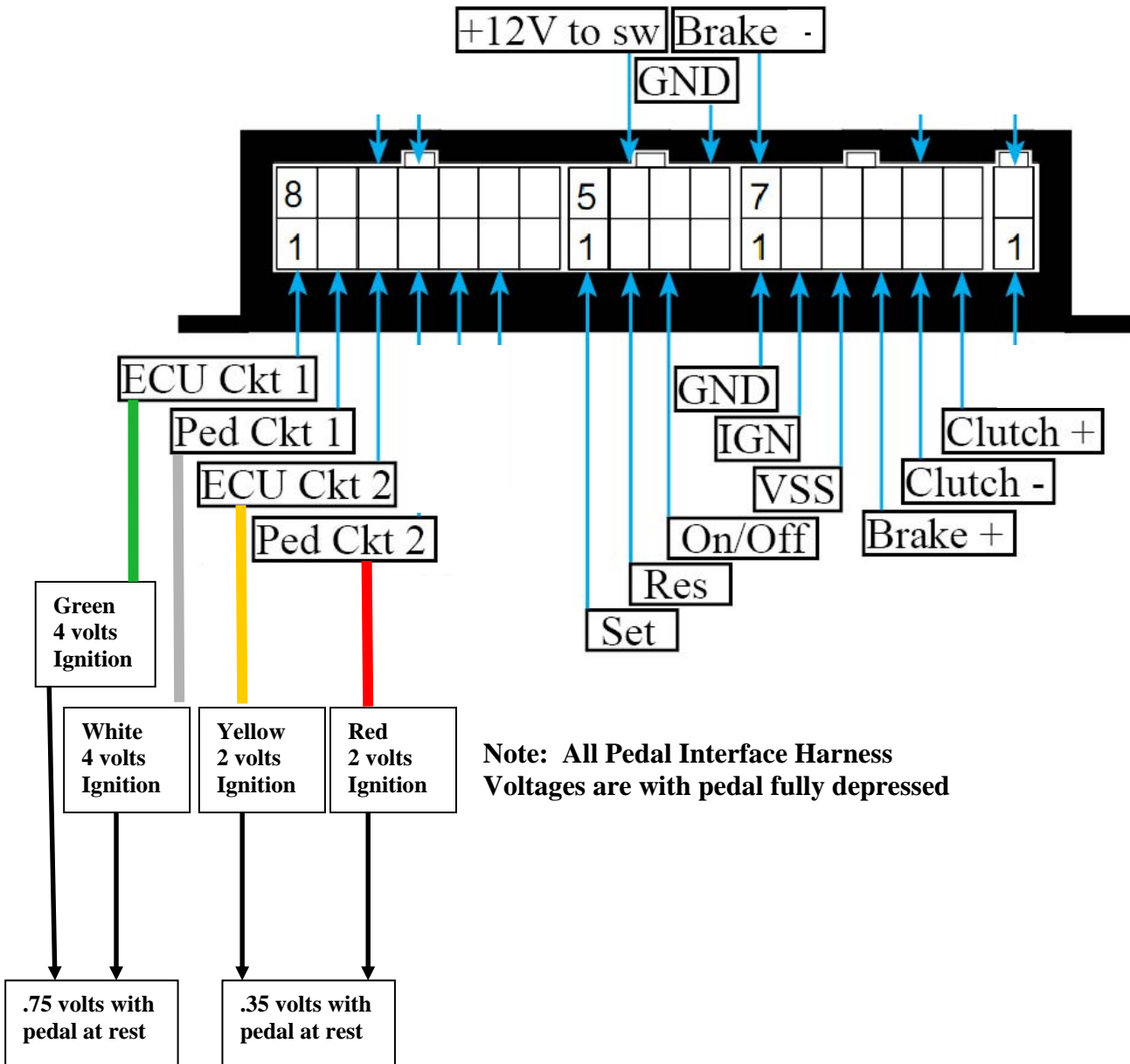

WIRING HARNESS DESCRIPTION

Function	Color	Results	Fault Conditions
Ignition	Red	+12V when switched on and +0V when switched off. Ignition must be greater than +10V while cranking vehicle.	No power, voltage drop, or intermittent connection will cause Loss of pedal or "Limp Mode" condition.
Brake positive +	Blue	"Hot" side of brake switch. +12V all the time.	Cruise will not function if this connection is not installed correctly.
Brake negative -	Brown/White	"Cold" side of Brake switch. Zero (0) resistance to ground when brake is not pressed. +12V when brake is pressed.	Cruise will not function if this connection is not installed correctly. If connection is good, and there is a high resistance to ground, a 5 terminal relay will be required to complete installation. See diagram below.
Ground	Black	Lowest resistance to ground closest to zero (0) ohms as possible. Use a vehicle ground point where other ground wires are connected to.	A bad ground connection will cause the following conditions: Cruise will not function; Loss of pedal or "Limp Mode" condition.
Clutch (GND triggered)	White	Ground active wire at switch when clutch is depressed.	Cruise will not function if wrong wire is connected –OR– ⚠️Cruise will not disengage when clutch is depressed.
Clutch (+12V triggered)	Yellow	+12V active wire at switch when clutch is depressed.	Cruise will not function if wrong wire is connected –OR– ⚠️Cruise will not disengage when clutch is depressed.

5 Terminal Relay for Brake Switch

